



Trench Drain Solutions



Supplied By:

**TRENCHDRAIN
SUPPLY**

877-903-7246

www.trenchdrainsupply.com

HYDROTEC ®
Technologies

Trench Drain Solutions

Introduction	7
– About SIGMA	8
– Certified Quality	9
– Load Classes	10 - 11
– System overview	12
– Trench Drain Calculator	13
Concrete Products	14
– The MINI System	15 - 16
*MINI 100 Products	17
*MINI SLOT 100	18
– The TOP System	19
*TOP 100 Products	20 - 22
*The MAXI System	23 - 24
*MAXI 100 Products	25 - 27
*MAXI 150 Products	28 - 29
*MAXI 200 Products	30 - 31
– Special Applications	32
*MAXI 300 Products	33 - 34
– HYDROline	35
– The HYDROblock System	36 - 37
Specifications	38
– MAXI100	39 - 41
– MAXI50	42 - 44
– MAX200	45 - 47
– MAXI300	48 - 49
– TOP100	50 - 53

Trench Drain Solutions

Technical Resources 54

- Hydraulic Calculation 55
- Flow Calculation 56
- Chemical Resistance Chart 57
- Environmental Impact 58 - 74

Additional Information 75

- Accessories 76
- FAQ's 77 - 79

Installation Instructions 80

- General Installation Instructions 81 - 82
- Expansion Joints Arrangement 83
- Trench Drain Runs Layout 84
- MINI 85
 - *TOP Class A-C ASPHALT 86
 - *TOP Class A-C ASPHALT/STONE/BRICK 87
 - *TOP Class A-C CONCRETE/PAVEMENT 88
- MAXI 89
 - *MAXI Class A-C ASPHALT 89
 - *MAXI Class A-C ASPHALT/STONE/BRICK 90
 - *MAXI Class A-C CONCRETE/PAVEMENT 91
 - *MAXI Class D-E-F 92
- HYDROline 93 - 94
- HYDOblock 95 - 96
- End Caps and Pipe Connections 97 - 99
- Installation at an Angle 100
- Installation at a Radium 101
- Detailed Installation Instructions
 - *MINI/TOP/MAXI 102
 - *MAXI 100/150/200/300 HYDROblock 100/200 103

Trench Drain Solutions

Plastic Products

104

- Polylok Introduction 105 - 107
- Polylok Products 108 - 111

Concrete Products

112

- Gatic M50 Heavy Industrial Introduction 113 - 116



Supplied By:

TRENCHDRAIN
SUPPLY

877-903-7246

www.trenchdrainsupply.com



Quality – Service – Commitment – Delivered.

www.sigmaco.com

Introduction

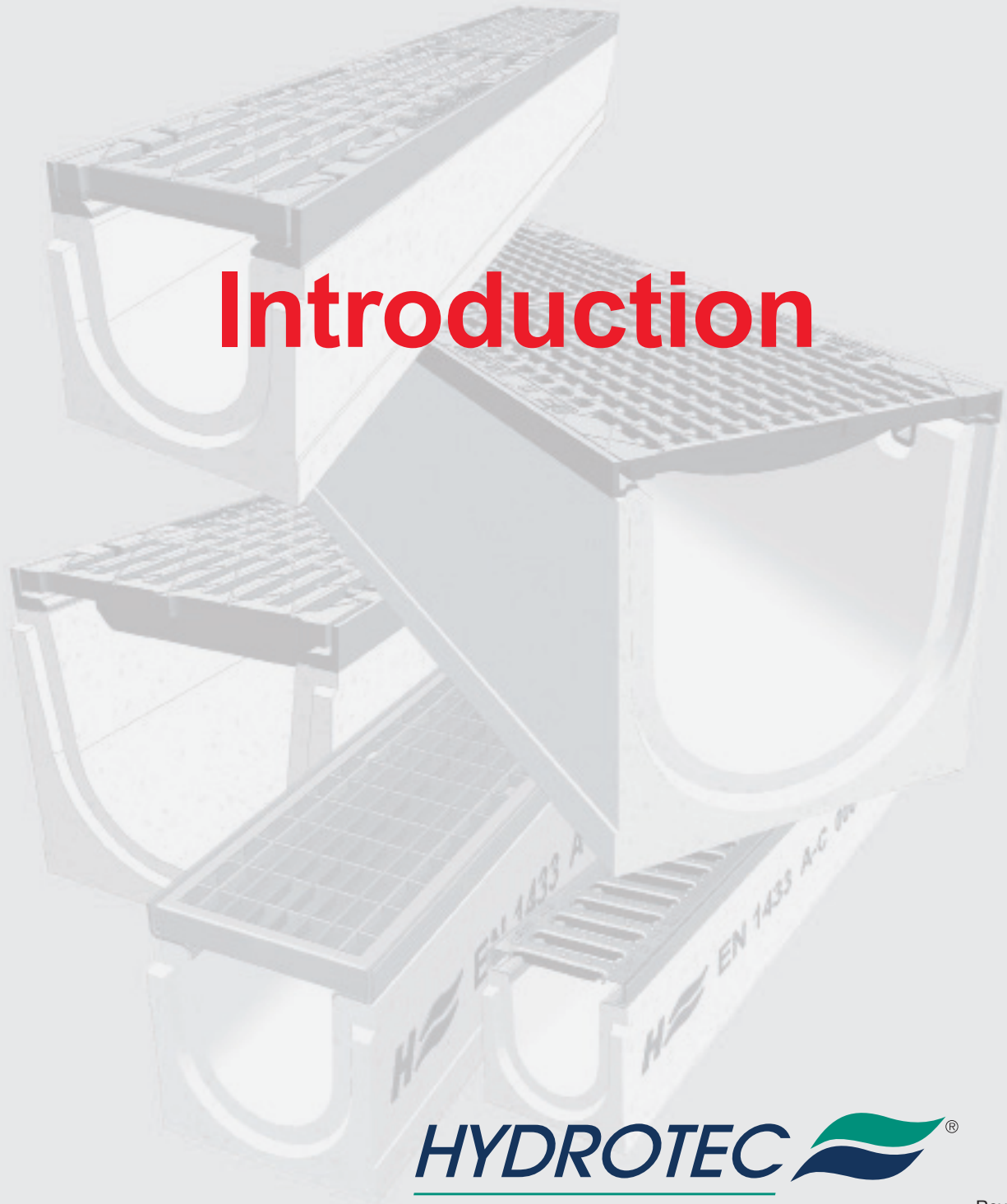

HYDROTEC ®
Technologies

Rev 4/30/15

About SIGMA

Quality - Service - Commitment - Delivered

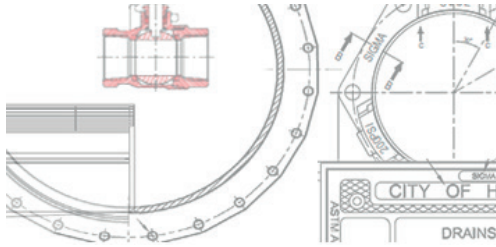

SIGMA Corporation has been developing products for the North American Water and Wastewater industry for over 25 years.

Today, we are one of the world's largest suppliers of specialty water products within the American Waterworks Association (AWWA) range.

At SIGMA, we are proud to offer the highest quality ductile iron waterworks fittings, pipe restraint products, municipal casting products and trench drain systems available on the market. We operate a network of warehouse and distribution offices that provides us with a national reach.

Our Partnership with HYDROTEC

SIGMA has grown rapidly through an increased focus on geographic expansion, and by broadening our extensive product line. We have recently complemented our portfolio by acquiring a number of new product lines to service the fire protection, plumbing, pump, valve and trench drain industries.

Our recent partnership with HYDROTEC, a leading manufacturer of Trench Drain Systems from Germany, broadens our business and plays to the strengths of the SIGMA team.

SIGMA is also an important OEM supplier to the water industry, working with our customers to develop value added and engineered solutions for the valve, hydrant, and pump sectors. We have leveraged OEM's synergies to expand our footprint outside water and castings in order to serve numerous customers across many different product categories. We deem all inquiries as worthy of review by our team and our vast and growing supply base.



Our Mission and our Commitment to our Customers

Our mission is to exceed our customers' expectations by focusing on the principles of quality and customer service. Commitment to our customer is the foundation on which these principles are based. We aim to be your trusted business partner, giving you confidence in our well engineered products. We are industry leaders in the field of quality testing, and seek to raise the bar on quality standards and manufacturing processes in our industry. The company has pioneered a quality control procedure that is the highest in the industry, relying on process controls, testing, and a unique heat coded marquee, displaying manufacturing data that is encoded at the time of manufacture.

At SIGMA we believe that quality is not a cost; rather it is an investment on behalf of our customers – and their customers. Because of our quality approach to manufacturing and to customer service, it pays to do business with us.

Supplied By:

**TRENCHDRAIN
SUPPLY**

877-903-7246
www.trenchdrainsupply.com

Certified Quality



Our products are tested for compliance with international standards and monitored by internationally accredited test laboratories.



Quality Management



We guarantee a high standard of safety as HYDROTEC is DIN EN 9001:2000 certified. HYDROTEC also fulfills the requirements of other international standards such as: ON-CERT, EMI and KIWA.

Our complete Trench Drain product range is internally and externally monitored for quality and approved according to DIN EN 124 and EN 1433.

SIGMA believes that quality does not cost, it pays. Our commitment to quality is to maximize the combined value of our service to each of our customers, by supplying all of our products to the highest requirements and standards of customer satisfaction. We strive to ensure that our products are delivered free of defects at a competitive price, with the utmost attention to all aspects of product development, production, and supply chain management

What we are proud of!



HYDROTEC's competence is not only well-known in Germany. HYDROTEC is now one of the biggest players on the European drainage technology market.

However, HYDROTEC has already established a foothold outside of Europe. In the Middle and Far East in particular, dealers, planners and contractors working on communal and private projects all rely on our quality "Made in Germany". The cable duct at the Schalke Arena soccer stadium, the covers on Palm Tree Island, or the trench drains for the Formula 1 racetracks in Shanghai and Istanbul are just some of HYDROTEC Technologies AG's reference projects.

These are results that can't be achieved with unkept promises. Performance and innovation are what it takes to convince others more than anything else.

General notes

Illustrations, dimensions and weights are provided without commitment. We reserve the right to modify the design and production methods to reflect the current state of art in technology. All previous catalogues become invalid on publication of this catalogue. All details concerning standards and kite marks were correct when this catalogue went to press.

Load Standard DIN19580 / EN 1433

DIN19580 is the only standard written specifically for trench drains, and that is internationally recognized.

DIN 19580 accounts for different widths of grates:

- For trench drains less than 8" wide, the required test block for load testing is 10" long by 3" wide;
- For trench drains 8" and 12" wide, the test block is 10" by 6";
- For trench drains over 12", the test block is 10" diameter.

This ensures that no load is transferred to the grate supports and the full force of the test load is directed onto the grate itself.

DIN 19580 is being superseded by EN 1433. EN 1433 tests products in exactly the same method as DIN 19580 with the same load categories, up to 202,320lbs - 4,182psi.

As with DIN 19580, EN 1433 offers testing methods for both the complete trench drain and individual grates. It accounts for both proof loading and catastrophic failure.

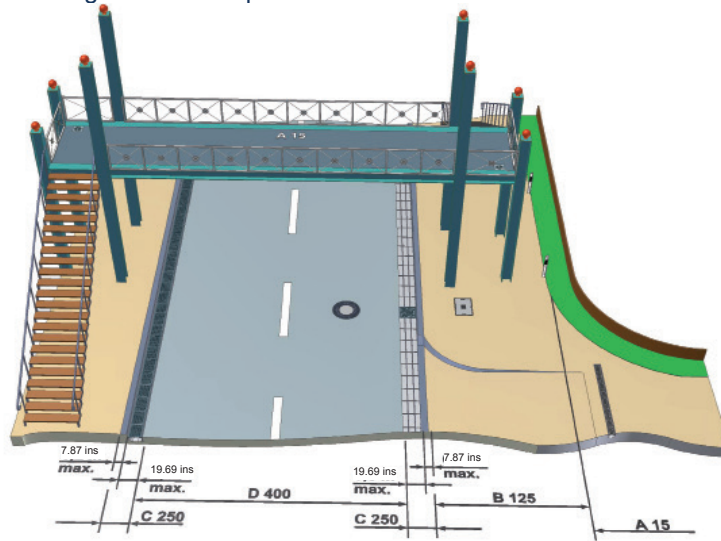

Load Classes: A, B, C, D, E and F.

Load Standard DIN19580 / EN1433 accounts for six different load classes, from lighter to heavier load: A, B, C, D, E and F.



Class A
15 kN / 3,372 lbs.
Residential areas used by pedestrians and cyclists.



Class D
400 kN / 89,920 lbs.
Roads and highways.



Class B
125 kN / 28,100 lbs.
Sidewalks, pedestrian areas and small parking lots.



Class E
600 kN / 134,800 lbs.
Industrial areas used by vehicles with a particularly wheel load, e.g. gas stations and loading dock facilities.



Class C
250 kN / 56,200 lbs.
Parking lots and general commercial areas.



Class F
900 kN / 202,320 lbs.
Special areas with heavy wheel loads, e.g. airports and docks.

HYDROTEC Trench Drain Product Line by Load Class



CLASS A
15 kN / 3,372 lbs

Residential areas used by pedestrians and cyclists.



CLASS B
125 kN / 28,100 lbs

Sidewalks, pedestrian areas and small parking lots.



CLASS C
250 kN / 56,200 lbs

Parking lots and general commercial areas.



CLASS D
400 kN / 89,920 lbs

Roads and highways.



CLASS E
600 kN / 134,800 lbs

Industrial areas used by vehicles with a particularly wheel load, e.g. gas stations and loading dock facilities.



CLASS F
900 kN / 202,320 lbs

Special areas with heavy wheel loads, e.g. airports and docks.

MINI



MINI100 (4'')

<p>A Galvanized Steel Slot ADA Grate</p>	<p>B Galvanized Steel Mesh Grate</p>
---	---

TOP



TOP100 (4'') LOAD CLASS A/C

- Galvanized Steel Slot ADA Grate (Load Classes A & C)
- Galvanized Steel Mesh Grate (Load Class C)
- Ductile Iron Grate (Load Class C)

MAXI



Ductile Iron ADA Grates

MAXI100 (4'') LOAD CLASS C/D/E/F

MAXI150 (6'') LOAD CLASS D/E/F

MAXI200 (8'') LOAD CLASS D/E/F

MAXI 300 (12'') LOAD CLASS E/F

HYDROblock

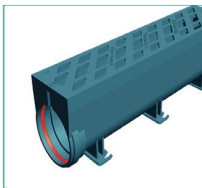

One piece Ductile Iron

HYDROblock 100 (4'') / 200 (8'') / 300 (12'') LOAD CLASS F

HYDROline

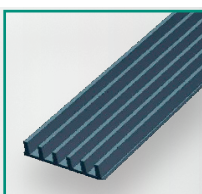

One piece Ductile Iron

HYDROline LOAD CLASS F

HYDROTEC Trench Drains at a Glance

- All trench drain channels are made out of fiber reinforced concrete (strength class C35/45).
- Available in 4", 6", 8" and 12" wide.
- Available in 39.37" (1 meter) and 19.69" long (0.5 meter)
- Available flat (all sizes) and pre-sloped (4" and 6" only).
- Load Classes A, B, C, D, E and F as per Load Standard DIN19580 / EN 1433
- Liquid-tight to EN 1433 standard.



Easy opening and closing from standing position



No "overshoot" thanks to longitudinal grating slots



Clean closure for any drainage channel

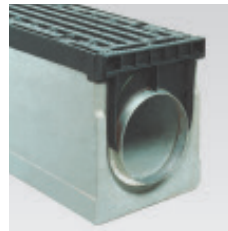

Easy connection to ground pipes

Advantages of Fiber Reinforced Concrete vs. Polymer Concrete

- + Less brittle than polymer concrete which drastically reduces breakage during transportation and installation.
- + Best of class foundation effect thanks to mass and U shape. The smooth outer surfaces guarantee best possible load transfer to the foundations.
- + The channels possess the same thermal expansion coefficients as the concrete encasement.
- + Low CO₂ emission and low energy requirement in manufacturing.
- + No need to hang or suspend the channels which, alongside HYDROTEC's patented locking mechanism, reduces time and installation costs.
- + Environmentally friendly, natural building product, fully recyclable.
- + Non-combustible.
- + Superior abrasion resilience compared with polymer concrete.

Trench Drain Quantity Calculator

Required Run Length	Number of 39.37" (1m) HYDROTEC Channels	Number of 19.69" (0.5m) HYDROTEC Channels	Actual HY-DROTEC Run Length
1'	0	1	1.64'
2'	0	1	1.64'
3'	1	0	3.28'
4'	1	0	3.28'
5'	1	1	4.92'
6'	2	0	6.56'
7'	2	0	6.56'
8'	2	1	8.20'
9'	3	0	9.84'
10'	3	0	9.84'
11'	3	1	11.48'
12'	3	1	11.48'
13'	4	0	13.12'
14'	4	0	13.12'
15'	4	1	14.76'
16'	5	0	16.40'
17'	5	0	16.40'
18'	5	1	18.04'
19'	6	0	19.69'
20'	6	0	19.69'
21'	6	1	21.33'
22'	7	0	22.97'
23'	7	0	22.97'
24'	7	1	24.61'
25'	7	1	24.61'
26'	8	0	26.25'
27'	8	0	26.25'
28'	8	1	27.89'
29'	8	1	27.89'
30'	9	0	29.53'
31'	9	1	31.17'
32'	9	1	31.17'
33'	10	0	32.81'
34'	10	1	34.45'
35'	10	1	34.45'
36'	11	0	36.09'
37'	11	1	37.73'
38'	11	1	37.73'
39'	12	0	39.37'
40'	12	0	39.37'
41'	12	1	41.01'
42'	13	0	42.65'
43'	13	1	44.29'
44'	13	1	44.29'
45'	14	0	45.93'
46'	14	0	45.93'
47'	14	1	47.57'
48'	14	1	47.57'
49'	15	0	49.21'
50'	15	1	50.85'

Required Run Length	Number of 39.37" (1m) HYDROTEC Channels	Number of 19.69" (0.5m) HYDROTEC Channels	Actual HY-DROTEC Run Length
51'	15	1	50.85'
52'	16	0	52.49'
53'	16	0	52.49'
54'	16	1	54.13'
55'	17	0	55.77'
56'	17	0	55.77'
57'	17	1	57.41'
58'	17	1	57.41'
59'	18	0	59.06'
60'	18	1	60.70'
61'	18	1	60.70'
62'	19	0	62.34'
63'	19	0	62.34'
64'	19	1	63.98'
65'	20	0	65.62'
66'	20	0	65.62'
67'	20	1	67.26'
68'	21	0	68.90'
69'	21	0	68.90'
70'	21	1	70.54'
71'	21	1	70.54'
72'	22	0	72.18'
73'	22	1	73.82'
74'	22	1	73.82'
75'	23	0	75.46'
76'	23	0	75.46'
77'	23	1	77.10'
78'	24	0	78.74'
79'	24	0	78.74'
80'	24	1	80.38'
81'	24	1	80.38'
82'	25	0	82.02'
83'	25	1	83.66'
84'	25	1	83.66'
85'	26	0	85.30'
86'	26	1	86.94'
87'	26	1	86.94'
88'	27	0	88.58'
89'	27	0	88.58'
90'	27	1	90.22'
91'	28	0	91.86'
92'	28	0	91.86'
93'	28	1	93.50'
94'	29	0	95.14'
95'	29	0	95.14'
96'	29	0	95.14'
97'	29	1	96.78'
98'	30	0	98.43'
99'	30	0	98.43'
100'	30	1	100.07'



Quality – Service – Commitment – Delivered.

www.sigmaco.com

CONCRETE PRODUCTS



Supplied By:

**TRENCHDRAIN
SUPPLY**

877-903-7246

www.trenchdrainsupply.com

HYDROTEC 

Technologies

Rev 4/30/15

MINI SYSTEM

Product Description

The MINI trench drain line is a simple modular system for uncomplicated D.I.Y. installation. These 4" wide flat trench drains are available in 39.37" (1 meter) and 19.69" (0.5 meters) long and they are easily joined together by connecting male and female profiles. Each channel section has a precast vertical outlet for 4" pipes. Available with galvanized steel slotted ADA and galvanized steel mesh grates that provide a neat transition from the trench drain to the adjoining road surface.

Apart from use in private and leisure areas, the MINI trench drain is also suitable for sports fields, pedestrian areas, courtyards and car parks. The grates are held firmly in the channels, avoiding jamming between the adjoining surfaces. The use of natural building materials guarantees environmental friendliness.

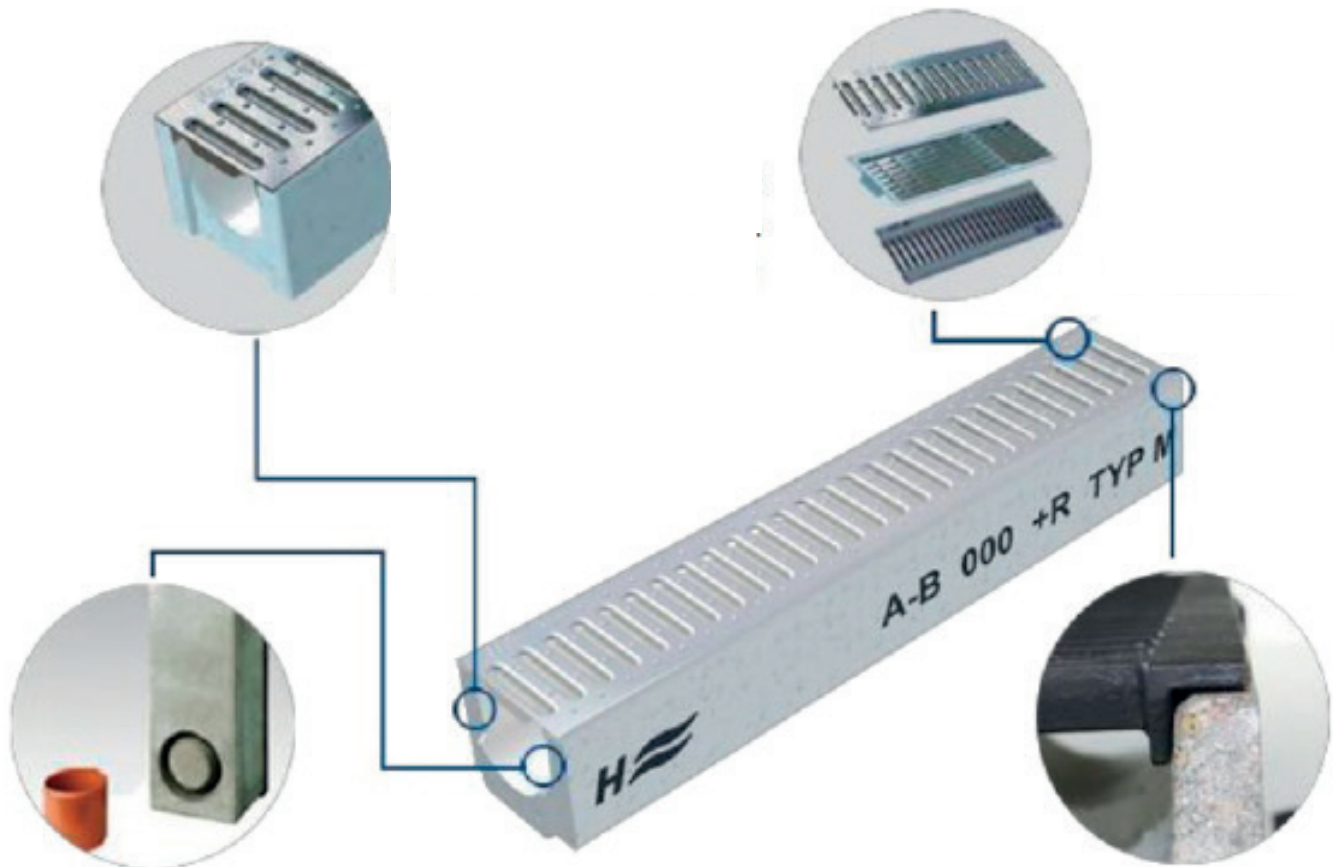

- Practical system for easy D.I.Y. installation
- Precast vertical outlet to connect 4" pipes in each section
- Frame incorporated in the grate
- Male and female channel profiles for easy fitting

Areas of Application

- **Sports Fields**
- **Shopping Malls**
- **Pedestrian Areas**
- **Domestic Driveways**
- **Industrial Kitchens**
- **Greenways**
- **Schools**
- **Hospitals**

MINI SYSTEM

Application Example: Aarhus Stadium, Denmark



MINI 100 SYSTEM (4")

MINI Load Class A with Galvanized Steel Slot Grate



Product range

Part Description	Part No.	Weight lbs	Overall Length Inches (mm)	Overall Depth Inches (mm)		Pieces per pallet
				Inlet	Outlet	
Drainage channel without slope	CHG64110-000	52.91	39.37" (1000)	4.72" (120)	4.72" (120)	48
	CHG64110-005	34.17	19.69" (500)	4.72" (120)	4.72" (120)	96
Catch Basin	CHG64110-008	63.93	19.69" (500)	14.29" (363)	14.29" (363)	10

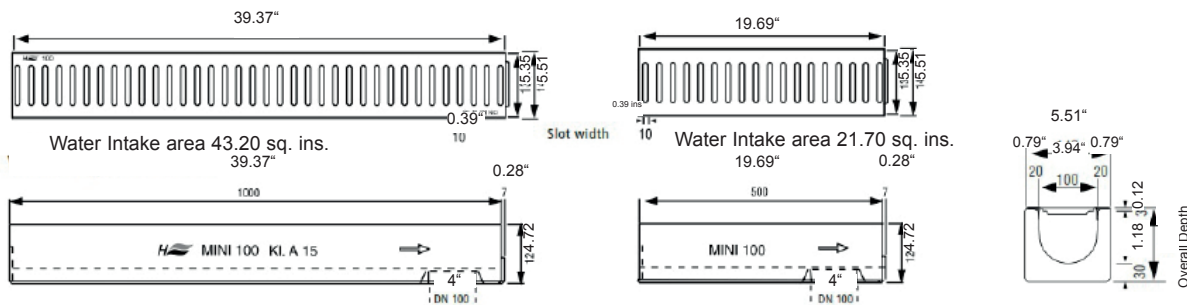

MINI Load Class B with Galvanized Steel Mesh Grate



Product range

Part Description	Part No.	Weight lbs	Overall Length Inches (mm)	Overall Depth Inches (mm)		Pieces per pallet
				Inlet	Outlet	
Drainage channel without slope	CHG64120-000	52.91	39.37" (1000)	4.72" (120)	4.72" (120)	48
	CHG64120-005	34.17	19.69" (500)	4.72" (120)	4.72" (120)	96
Catch Basin	CHG64120-008	63.93	19.69" (500)	14.29" (363)	14.29" (363)	10

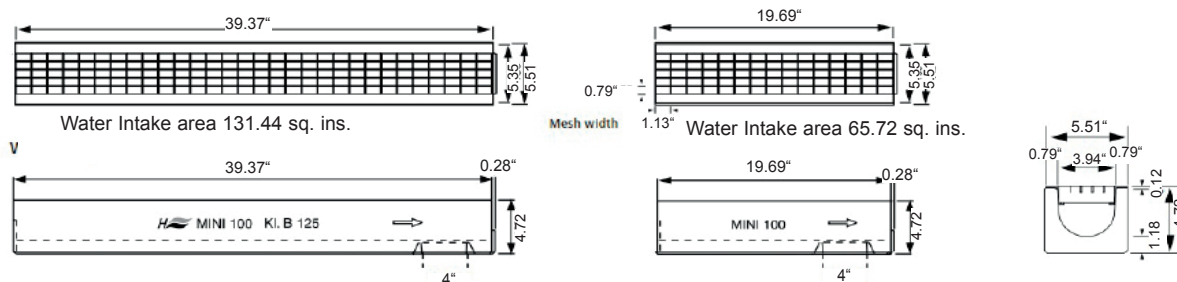
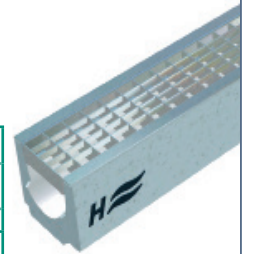

Accessories MINI Load Class A & B

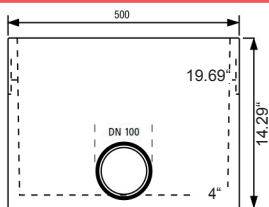

Catch Basin includes galvanized dirt catcher
 CHG64110-008 (Class A)
 CHG64120-008 (Class B)



End Piece
 Galvanized Steel
 Part.No.: CHG70016-00



4" Pipe Connector
 Part.No.: CHG70021-00



Foul air stop 4"
 Part.No.: CHG70031-00

MINI SLOT 100

MINI SLOT 100

Product range

Part Description	Part No.	Weight lbs	Overall Length inches (mm)	Overall Depth Inches (mm)		Pieces per pallet
				Inlet	Outlet	
Drainage channel without slope	CHG6413-1000	52.91	39.37" (1000)	8.27" (210)	8.27" (210)	48
	CHG6413-1005	33.07	19.69" (500)	8.27" (210)	8.27" (210)	96
Galvanized Steel Catch Basin	CHG6413-1008	63.93	19.69" (500)	8.27" (210)	8.27" (210)	-
Drainage channel without slope	CHG6413-2000	52.91	39.37" (1000)	8.27" (210)	8.27" (210)	48
	CHG6413-2005	33.07	19.69" (500)	8.27" (210)	8.27" (210)	96
Stainless steel Catch Basin	CHG6413-2008	63.93	19.69" (500)	8.27" (210)	8.27" (210)	-

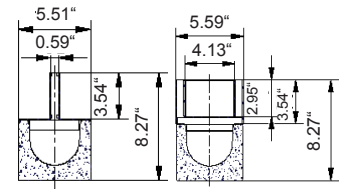
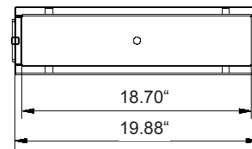
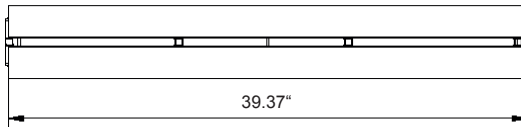
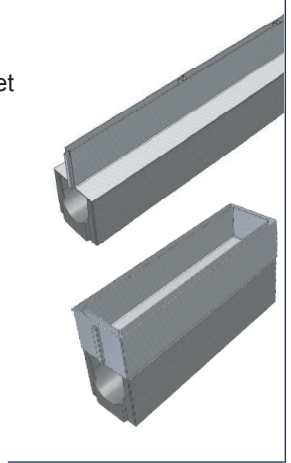

MINI SLOT 100, sideways

Product range

Part Description	Part No.	Weight lbs	Overall Length inches (mm)	Overall Depth Inches (mm)		Pieces per pallet
				Inlet	Outlet	
Drainage channel without slope	CHG6413-3000	52.91	39.37" (1000)	9.45" (240)	9.45" (240)	48
	CHG6413-3005	33.07	19.69" (500)	9.45" (240)	9.45" (240)	96
Galvanized Steel Catch Basin	CHG6413-3008	63.93	19.69" (500)	9.45" (240)	9.45" (240)	-
Drainage channel without slope	CHG6413-4000	52.91	39.37" (1000)	9.45" (240)	9.45" (240)	48
	CHG6413-4005	33.07	19.69" (500)	9.45" (240)	9.45" (240)	96
Stainless steel Catch Basin	CHG6413-4008	63.93	19.69" (500)	9.45" (240)	9.45" (240)	-

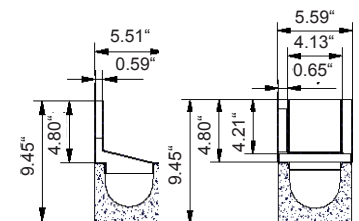
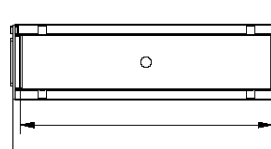
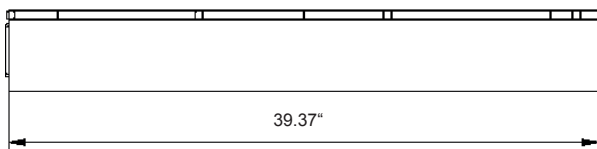
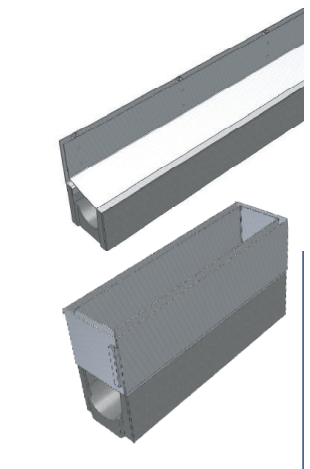

TOP SYSTEM

Product Description

The TOP trench drain line is a modular system for pedestrian areas, parking lots, general commercial areas and sport fields. These 4" wide trench drains are available in 39.37" (1000mm) and 19.69" (500mm) long, flat or pre-sloped and they are easily joined together by connecting male and female profiles.

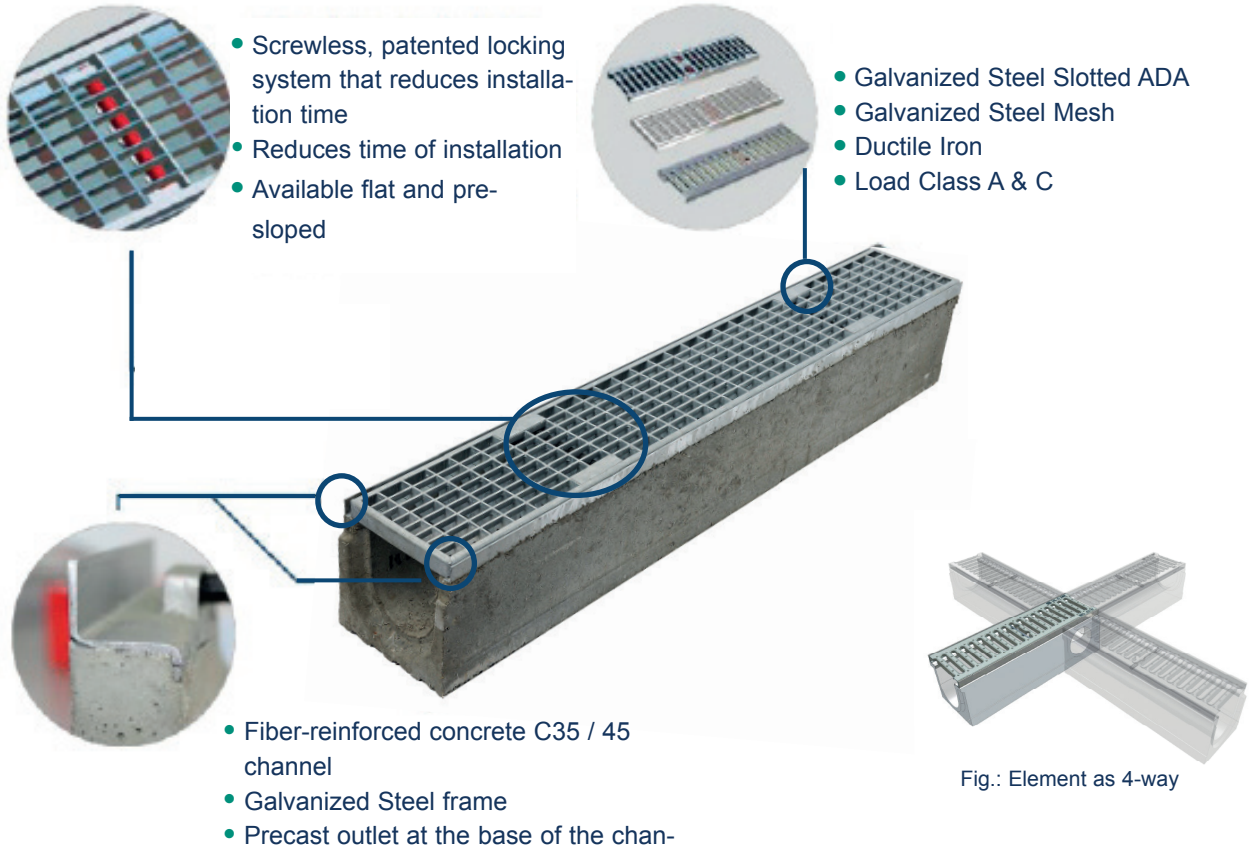

Areas of Application

- Sport Facilities and Stadiums
- Cycle paths and footpaths
- School yards
- Car parks
- Commercial
- Industrial

Guide to Pre-Sloped Modular System

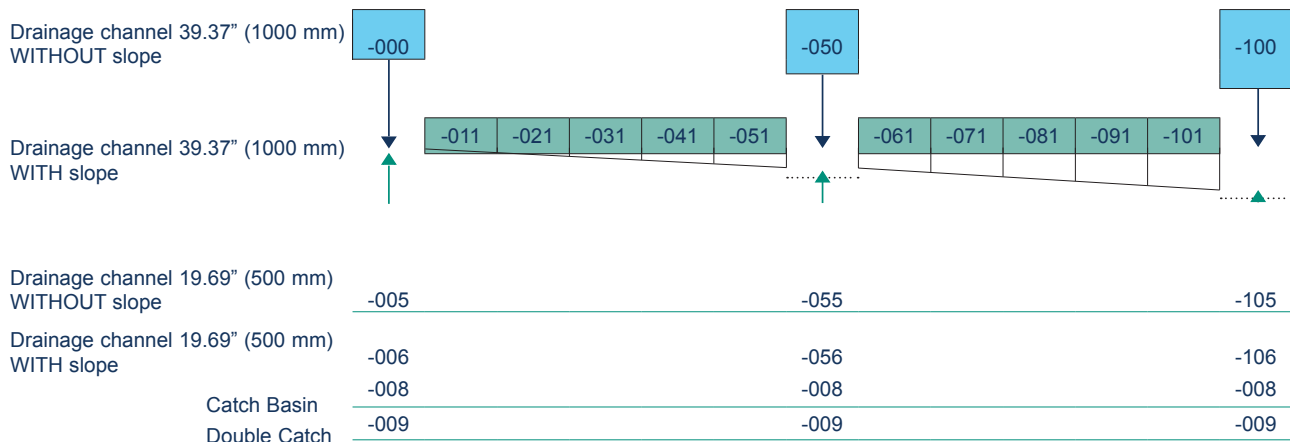

TOP 100 SYSTEM (4")

TOP 100 (4") with Galvanized Steel Slotted ADA Load Class A & C Grate and Galvanized Steel Frame



Product range

Part Description	Overall Depth Inches (mm)	Load Class A Part No.	Weight lbs	Load Class C Part No.	Weight lbs	Overall Inches Inlet	Depth (mm) Outlet	Pieces per pallet
Channel 39.37" (1m)	6.30" (160)	CHG63210-000	70.55	CHG63430-000	76.06	6.30"(160)	6.30"(160)	24
Channel 19.69" (0.5m)		CHG63210-005	35.27	CHG63430-005	38.58	6.30"(160)	6.30"(160)	48
Channel 19.69"(0.5m) with Side Opening		CHG63210-006	34.17	CHG63430-006	36.38	6.30"(160)	6.30"(160)	48
Channel 39.37" (1m)	7.28" (185)	CHG63210-050	82.67	CHG63430-050	88.18	7.28"(185)	7.28"(185)	24
Channel 19.69" (0.5m)		CHG63210-055	41.89	CHG63430-055	45.19	7.28"(185)	7.28"(185)	48
Channel 19.69"(0.5m) with Side Opening		CHG63210-056	39.68	CHG63430-056	42.99	7.28"(185)	7.28"(185)	48
Channel 39.37" (1m)	8.27" (210)	CHG63210-100	95.90	CHG63430-100	102.51	8.27"(210)	8.27"(210)	24
Channel 19.69" (0.5m)		CHG63210-105	46.30	CHG63430-105	49.60	8.27"(210)	8.27"(210)	48
Channel 19.69"(0.5m) with Side Opening		CHG63210-106	44.09	CHG63430-106	47.40	8.27"(210)	8.27"(210)	48
Catch Basin 19.69" (0.5m)	19.69" (500)	CHG63210-008	100.31	CHG63430-008	103.62	19.69"(500)	19.69"(500)	10
Channels with 0.5% Slope 39.37"(1m)		CHG63210-011	73.85	CHG63430-011	80.47	6.30"(160)	6.50"(165)	24
		CHG63210-021	76.06	CHG63430-021	81.57	6.50"(165)	6.69"(170)	24
		CHG63210-031	78.26	CHG63430-031	83.78	6.69"(170)	6.89"(175)	24
		CHG63210-041	79.37	CHG63430-041	84.88	6.89"(175)	7.09"(180)	24
		CHG63210-051	81.57	CHG63430-051	87.08	7.09"(180)	7.28"(185)	24
Channels with 0.5% Slope 39.37"(1m)		CHG63210-061	83.78	CHG63430-061	89.29	7.28"(185)	7.48"(190)	24
		CHG63210-071	87.08	CHG63430-071	92.59	7.48"(190)	7.68"(195)	24
		CHG63210-081	88.18	CHG63430-081	93.70	7.68"(195)	7.87"(200)	24
		CHG63210-091	92.59	CHG63430-091	98.11	7.87"(200)	8.07"(205)	24
		CHG63210-101	94.80	CHG63430-101	100.31	8.07"(205)	8.27"(210)	24

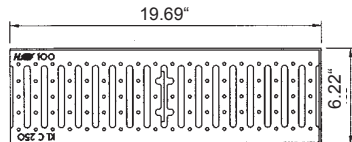
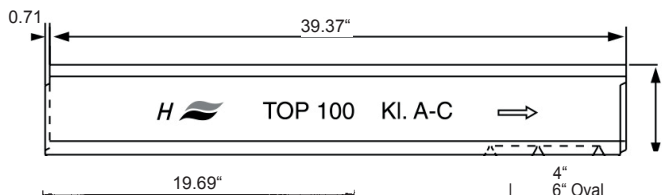

Water Intake area 27.82 sq. ins.

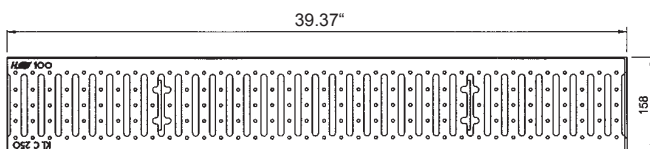

Water Intake area 55.65 sq. ins.

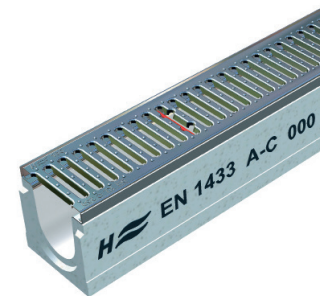
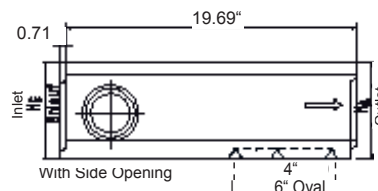
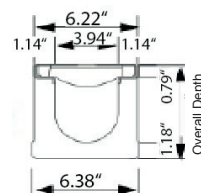

TOP100 (4") with Galvanized Steel Slot ADA Grate

TOP 100 SYSTEM (4")

TOP 100 (4") with Galvanized Steel Mesh Load Class C Grate and Galvanized Steel Frame



Product range

Part Description	Overall Depth Inches (mm)	Load Class C Part No.	Weight lbs	Overall Depth Inches (mm)		Pieces per pallet
				Inlet	Outlet	
Channel 39.37" (1m)	6.30" (160)	CHG63230-000	74.96	6.30"(160)	6.30"(160)	24
Channel 19.69" (0.5m)		CHG63230-005	37.48	6.30"(160)	6.30"(160)	48
Channel 19.69"(0.5m) with Side Opening		CHG63230-006	35.27	6.30"(160)	6.30"(160)	48
Channel 39.37" (1m)	7.28" (185)	CHG63230-050	87.08	7.28"(185)	7.28"(185)	24
Channel 19.69" (0.5m)		CHG63230-055	44.09	7.28"(185)	7.28"(185)	48
Channel 19.69"(0.5m) with Side Opening		CHG63230-056	41.89	7.28"(185)	7.28"(185)	48
Channel 39.37" (1m)	8.27" (210)	CHG63230-100	100.31	8.27"(210)	8.27"(210)	24
Channel 19.69" (0.5m)		CHG63230-105	48.50	8.27"(210)	8.27"(210)	48
Channel 19.69"(0.5m) with Side Opening		CHG63230-106	46.30	8.27"(210)	8.27"(210)	48
Catch Basin 19.69" (0.5m)	19.69" (500)	CHG63230-008	103.62	19.69"(500)	19.69"(500)	10
Channels with 0.5% Slope 39.37"(1m)	6.30"(160) - 7.28"(185)	CHG63230-011	78.26	6.30"(160)	6.50"(165)	24
		CHG63230-021	80.47	6.50"(165)	6.69"(170)	24
		CHG63230-031	82.67	6.69"(170)	6.89"(175)	24
		CHG63230-041	83.78	6.89"(175)	7.09"(180)	24
		CHG63230-051	85.98	7.09"(180)	7.28"(185)	24
Channels with 0.5% Slope 39.37"(1m)	7.28"(185) - 8.27"(210)	CHG63230-061	88.18	7.28"(185)	7.48"(190)	24
		CHG63230-071	91.49	7.48"(190)	7.68"(195)	24
		CHG63230-081	92.59	7.68"(195)	7.87"(200)	24
		CHG63230-091	98.11	7.87"(200)	8.07"(205)	24
		CHG63230-101	99.21	8.07"(205)	8.27"(210)	24

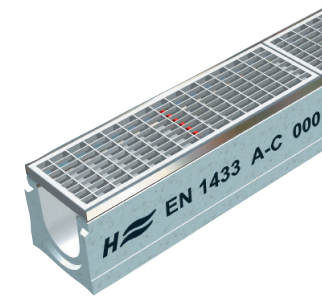
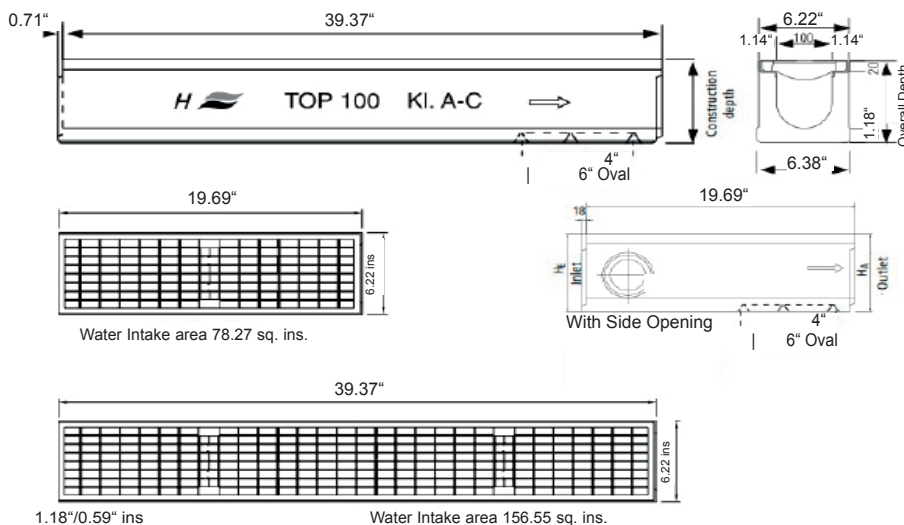

TOP100 (4") with Galvanized Steel Mesh Grate

Supplied By:

TOP 100 SYSTEM (4")

TOP 100 (4") with Ductile Iron Load Class C Grate and Galvanized Steel Frame



Product range

Part Description	Overall Depth Inches (mm)	Load Class C Part No.	Weight lbs	Overall Inches Inlet	Overall Depth (mm) Inlet Outlet	Pieces per Pallet
Channel 39.37" (1m)	6.30" (160)	CHG63130-000	102.74	6.30"(160)	6.30"(160)	24
Channel 19.69" (0.5m)		CHG63130-005	50.71	6.30"(160)	6.30"(160)	48
Channel 19.69"(0.5m) with Side Opening		CHG63130-006	49.60	6.30"(160)	6.30"(160)	48
Channel 39.37" (1m)	7.28" (185)	CHG63130-050	108.47	7.28"(185)	7.28"(185)	24
Channel 19.69" (0.5m)		CHG63130-055	57.32	7.28"(185)	7.28"(185)	48
Channel 19.69"(0.5m) with Side Opening		CHG63130-056	56.22	7.28"(185)	7.28"(185)	48
Channel 39.37" (1m)	8.27" (210)	CHG63130-100	116.62	8.27"(210)	8.27"(210)	24
Channel 19.69" (0.5m)		CHG63130-105	59.52	8.27"(210)	8.27"(210)	48
Channel 19.69"(0.5m) with Side Opening		CHG63130-106	58.42	8.27"(210)	8.27"(210)	48
Catch Basin 19.69" (0.5m)	19.69" (500)	CHG63130-008	112.44	19.69"(500)	19.69"(500)	10
Channels with 0.5% Slope 39.37"(1m)	6.30"(160) - 7.28"(185)	CHG63130-011	103.62	6.30"(160)	6.50"(165)	24
		CHG63130-021	104.72	6.50"(165)	6.69"(170)	24
		CHG63130-031	105.82	6.69"(170)	6.89"(175)	24
		CHG63130-041	106.92	6.89"(175)	7.09"(180)	24
Channels with 0.5% Slope 39.37"(1m)	7.28"(185) - 8.27"(210)	CHG63130-061	109.57	7.28"(185)	7.48"(190)	24
		CHG63130-071	111.33	7.48"(190)	7.68"(195)	24
		CHG63130-081	112.88	7.68"(195)	7.87"(200)	24
		CHG63130-091	114.42	7.87"(200)	8.07"(205)	24
CHG63130-101	115.96	8.07"(205)	8.27"(210)	24		



TOP100 (4") with Ductile Iron Grate

Accessories for ALL TOP 100

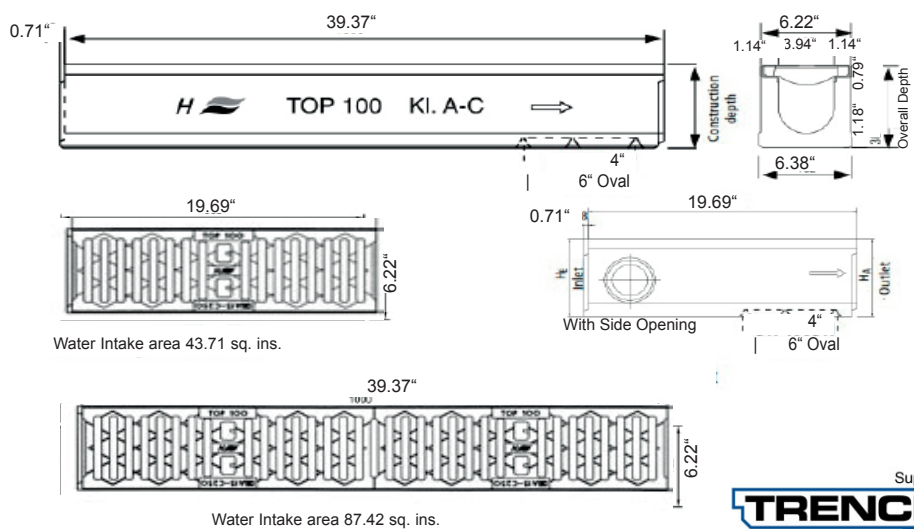
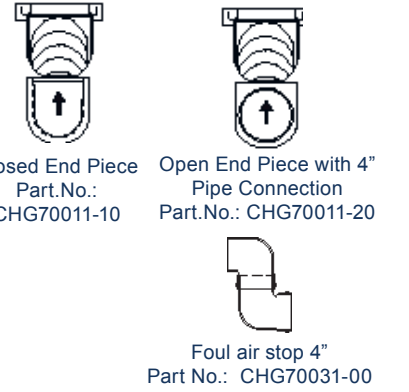
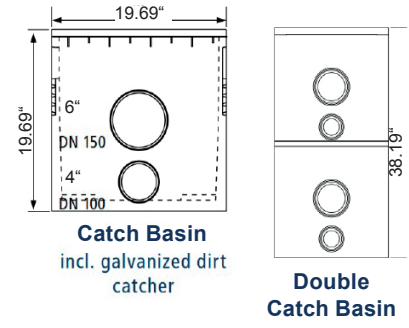

MAXI SYSTEM

Product Description

The MAXI trench drain system is ideal for heavy duty applications thanks to its ductile iron frame and grates. With a choice of load classes C, D, E or F, the MAXI system excels at projects requiring the maximum resistance and load bearing capabilities.

Sizes 4", 6", 8" or 12" wide trench drains are available in 39.37" (1000mm) and 19.69" (500mm) long and they are easily joined together by connecting male and female profiles.

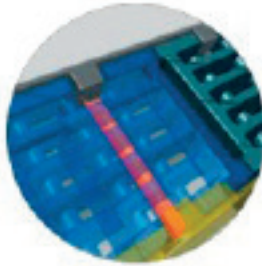

- Screwless, patented locking system that reduces time of installation
- Channels available in 4", 6", 8" and 12" wide
- Available flat (all sizes) and pre-sloped (4" and 6" only)



- Ductile Iron Grates
- Available in ADA and Heel Proof
- Longitudinal or Cross Slots
- Load Class C, D, E and F
- High Water Absorption



- Fiber-reinforced concrete C35 / 45 channel
- Ductile Iron Frame
- Precast outlet for a vertical connection to 4" and 6" pipes
- Connecting male and female profiles for precise fit

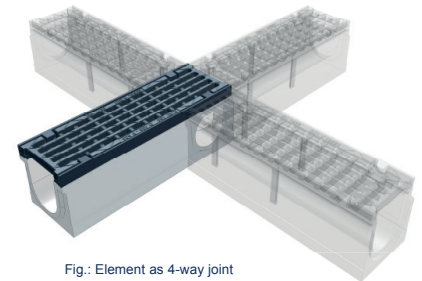
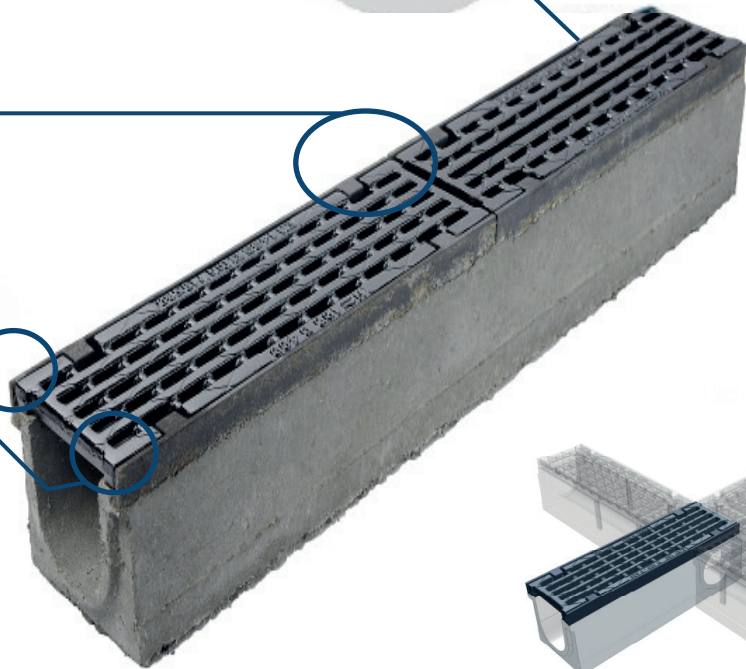

Fig.: Element as 4-way joint

Areas of Application

- Roads and Highways
- Industrial areas with heavy goods traffic
- Car parks
- Airports
- Public Transportation
- Shipping Terminals
- Sports Complex

MAXI SYSTEM

Product Applications

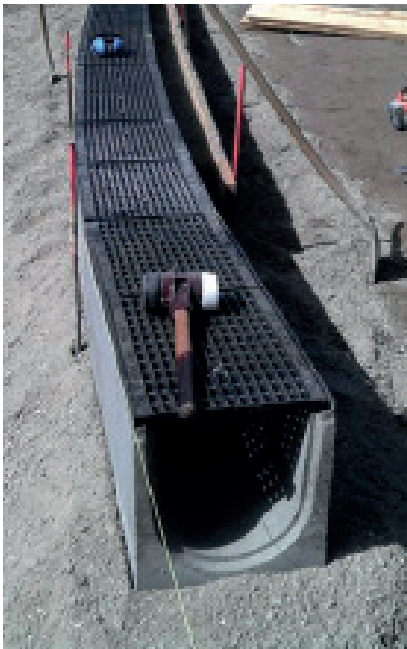

Modular System

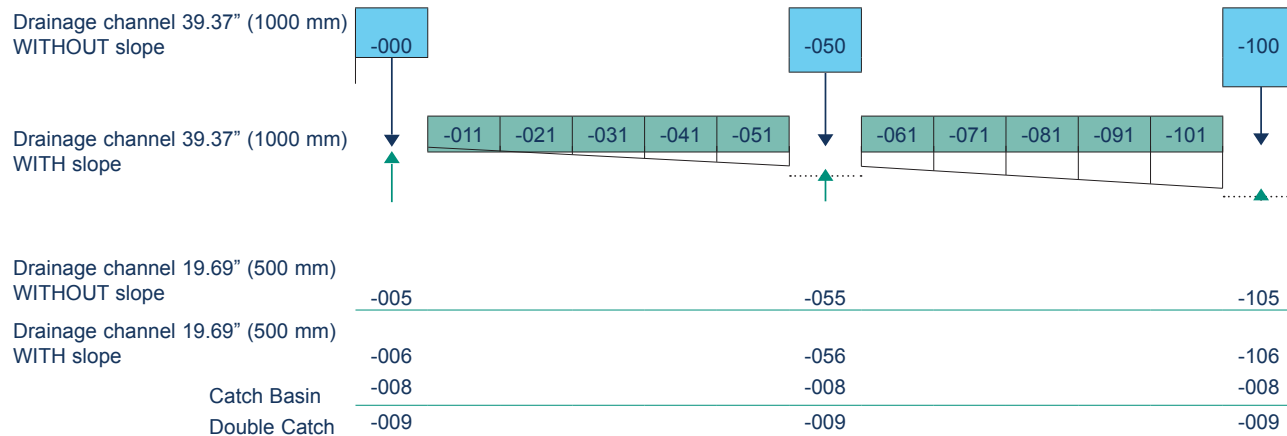

MAXI 100 SYSTEM (4")

MAXI 100 (4") with Ductile Iron Load Class C ADA Grate and Ductile Iron Frame



Product range

Part Description	Overall Depth Inches (mm)	Load Class C Part No. C	Weight lbs	Overall Depth Inches (mm) Inlet	Overall Depth Inches (mm) Outlet	Pieces per pallet
Channel 39.37" (1m)	6.30" (160)	CHG61131-000	99.21	6.30"(160)	6.30"(160)	24
Channel 19.69" (0.5m)		CHG61131-005	54.01	6.30"(160)	6.30"(160)	48
Channel 19.69"(0.5m) with Side Opening		CHG61131-006	45.19	6.30"(160)	6.30"(160)	48
Channel 39.37" (1m)	7.28" (185)	CHG61131-050	108.03	7.28"(185)	7.28"(185)	24
Channel 19.69" (0.5m)		CHG61131-055	51.81	7.28"(185)	7.28"(185)	48
Channel 19.69"(0.5m) with Side Opening		CHG61131-056	51.81	7.28"(185)	7.28"(185)	48
Channel 39.37" (1m)	8.27" (210)	CHG61131-100	119.05	8.27"(210)	8.27"(210)	24
Channel 19.69" (0.5m)		CHG61131-105	54.01	8.27"(210)	8.27"(210)	48
Channel 19.69"(0.5m) with Side Opening		CHG61131-106	54.01	8.27"(210)	8.27"(210)	48
Catch Basin 19.69" (0.5m)	19.69" (500)	CHG61131-008	109.13	19.69"(500)	19.69"(500)	10
Channels with 0.5% Slope 39.37"(1m)	6.30"(160) - 7.28"(185)	CHG61131-011	98.11	6.30"(160)	6.50"(165)	24
		CHG61131-021	98.11	6.50"(165)	6.69"(170)	24
		CHG61131-031	98.11	6.69"(170)	6.89"(175)	24
		CHG61131-041	99.21	6.89"(175)	7.09"(180)	24
Channels with 0.5% Slope 39.37"(1m)	7.28"(185) - 8.27"(210)	CHG61131-051	101.41	7.09"(180)	7.28"(185)	24
		CHG61131-061	103.62	7.28"(185)	7.48"(190)	24
		CHG61131-071	106.92	7.48"(190)	7.68"(195)	24
		CHG61131-081	108.03	7.68"(195)	7.87"(200)	24
Channels with 0.5% Slope 39.37"(1m)	8.27"(210)	CHG61131-091	111.33	7.87"(200)	8.07"(205)	24
		CHG61131-101	114.64	8.07"(205)	8.27"(210)	24



MAXI 100 (4") with Load Class C Ductile Iron grate with cross slots

Accessories for ALL MAXI 100 Load Class C, D, E and F

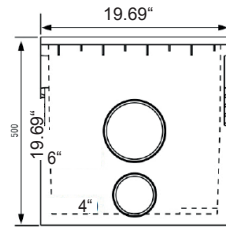

Catch Basin incl. galvanized debris basket

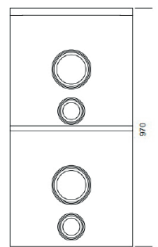

Double Catch Basin



Closed End Piece
Part.No.: CHG70011-10



Open End Piece with 4" Pipe Connection
Part.No.: CHG70011-20

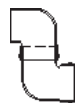

Foul air stop 4"
Part.No.: CHG70031-00

Channel with 2 grates, water intake area 85.87 sq. ins

39.37"

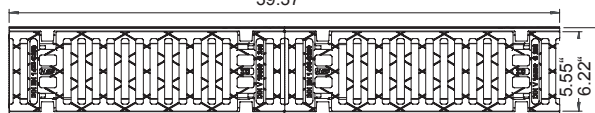

Water Intake area 42.93 sq. ins.

19.69"

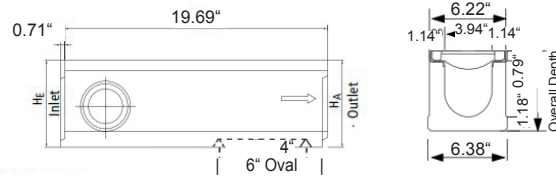
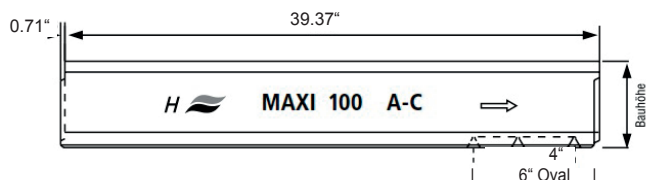
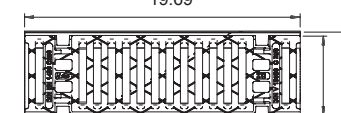

MAXI 100 (4") with Ductile Iron ADA Load Class D & F Grate and Ductile Iron Frame



Product range

Part Description	Overall Depth Inches (mm)	Load Class D Part No.	Weight lbs	Load Class F Part No.	Weight lbs	Overall Depth Inches (mm)		Pieces per pallet
						Inlet	Outlet	
Channel 39.37" (1m)	6.30" (160)	CHG61140-000	112.44	CHG61160-000	112.44	6.30"(160)	6.30"(160)	24
Channel 19.69" (0.5m)		CHG61140-005	51.81	CHG61160-005	51.81	6.30"(160)	6.30"(160)	48
19.69" with Side Opening		CHG61140-006	50.71	CHG61160-006	50.71	6.30"(160)	6.30"(160)	48
Channel 39.37" (1m)	7.28" (185)	CHG61140-050	122.36	CHG61160-050	122.36	7.28"(185)	7.28"(185)	24
Channel 19.69" (0.5m)		CHG61140-055	58.42	CHG61160-055	58.42	7.28"(185)	7.28"(185)	48
19.69" with Side Opening		CHG61140-056	57.32	CHG61160-056	57.32	7.28"(185)	7.28"(185)	48
Channel 39.37" (1m)	8.27" (210)	CHG61140-100	133.38	CHG61160-100	133.38	8.27"(210)	8.27"(210)	24
Channel 19.69" (0.5m)		CHG61140-105	49.60	CHG61160-105	49.60	8.27"(210)	8.27"(210)	48
19.69" with Side Opening		CHG61140-106	47.40	CHG61160-106	47.40	8.27"(210)	8.27"(210)	48
Channel 39.37" (1m)	9.25" (235)	CHG61140-150	137.79	CHG61160-150	137.79	9.25"(235)	9.25"(235)	24
Channel 19.69" (0.5m)		CHG61140-155	68.34	CHG61160-155	68.34	9.25"(235)	9.25"(235)	48
19.69" with Side Opening		CHG61140-156	68.34	CHG61160-156	68.34	9.25"(235)	9.25"(235)	48
Channel 39.37" (1m)	10.23" (260)	CHG61140-200	143.30	CHG61160-200	143.30	10.23"(260)		24
Channel 19.69" (0.5m)		CHG61140-205	71.65	CHG61160-205	71.65	10.23"(260)		48
19.69" with Side Opening		CHG61140-206	71.65	CHG61160-206	71.65	10.23"(260)		48
Catch Basin 19.69" (0.5m)	19.69" (500)	CHG61140-008	114.64	CHG61160-008	114.64	19.69"(500)		10
Channels with 0.5% Slope 39.37"(1m)	6.30"(160) - 7.28"(185)	-011	106.92	-011	113.54	6.30"(160)	6.50"(165)	24
		-021	109.13	-021	115.74	6.50"(165)	6.69"(170)	24
		-031	111.33	-031	117.95	6.69"(170)	6.89"(175)	24
		-041	112.44	-041	120.15	6.89"(175)	7.09"(180)	24
		-051	114.64	-051	122.36	7.09"(180)	7.28"(185)	24
Channels with 0.5% Slope 39.37"(1m)	7.28"(185) - 8.27"(210)	-061	116.84	-061	124.56	7.28"(185)	7.48"(190)	24
		-071	120.15	-071	126.77	7.48"(190)	7.68"(195)	24
		-081	121.25	-081	128.97	7.68"(195)	7.87"(200)	24
		-091	124.56	-091	131.18	7.87"(200)	8.07"(205)	24
		-101	127.87	-101	133.38	8.07"(205)	8.27"(210)	24

Channel with 2 grates, water intake area 79.36 sq. ins

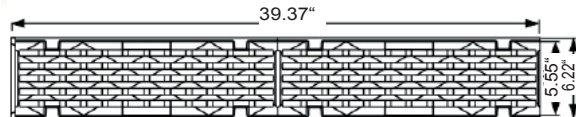

Water intake area 39.68 sq. ins

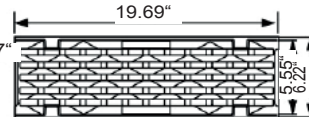

Slot width 0.47"

MAXI 100 (4") with Load Class F Ductile Iron grate with longitudinal slots

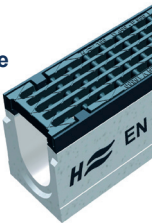
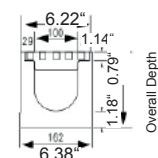
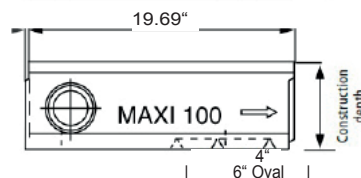
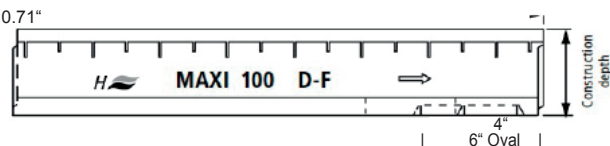

MAXI 100 SYSTEM (4")

MAXI 100 (4") with Ductile Iron Load Class E Mesh Grate and Ductile Iron Frame



Product range

Part Description	Overall Depth Inches (mm)	Load Class E Part No.	Weight lbs	Overall Depth Inches (mm)		Pieces per pallet
				Inlet	Outlet	
Channel 39.37" (1m)	6.30" (160)	CHG62150-000	112.44	6.30"(160)	6.30"(160)	24
Channel 19.69" (0.5m)		CHG62150-005	51.81	6.30"(160)	6.30"(160)	48
19.69" with Side Opening		CHG62150-006	50.71	6.30"(160)	6.30"(160)	48
Channel 39.37" (1m)	7.28" (185)	CHG62150-050	122.36	7.28"(185)	7.28"(185)	24
Channel 19.69" (0.5m)		CHG62150-055	58.42	7.28"(185)	7.28"(185)	48
19.69"with Side Opening		CHG62150-056	57.32	7.28"(185)	7.28"(185)	48
Channel 39.37" (1m)	8.27" (210)	CHG62150-100	133.38	8.27"(210)	8.27"(210)	24
Channel 19.69" (0.5m)		CHG62150-105	59.52	8.27"(210)	8.27"(210)	48
19.69" with Side Opening		CHG62150-106	62.83	8.27"(210)	8.27"(210)	48
Channel 39.37" (1m)	9.25" (235)	CHG62150-150	137.79	9.25"(235)	9.25"(235)	24
Channel 19.69" (0.5m)		CHG62150-155	68.34	9.25"(235)	9.25"(235)	48
19.69"with Side Opening		CHG62150-156	68.34	9.25"(235)	9.25"(235)	48
Channel 39.37" (1m)	10.23" (260)	CHG62150-200	143.30	10.23"(260)	10.23"(260)	24
Channel 19.69" (0.5m)		CHG62150-205	71.65	10.23"(260)	10.23"(260)	48
19.69" with Side Opening		CHG62150-206	71.65	10.23"(260)	10.23"(260)	48
Catch Basin 19.69" (0.5m)	19.69" (500)	CHG62150-008	114.64	19.69"(500)	19.69"(500)	10
Channels with 0.5% Slope 39.37"(1m)	6.30"(160) - 7.28"(185)	CHG62150-011	106.92	6.30"(160)	6.50"(165)	24
		CHG62150-021	109.13	6.50"(165)	6.69"(170)	24
		CHG62150-031	111.33	6.69"(170)	6.89"(175)	24
		CHG62150-041	112.44	6.89"(175)	7.09"(180)	24
		CHG62150-051	114.64	7.09"(180)	7.28"(185)	24
Channels with 0.5% Slope 39.37"(1m)	7.28"(185) - 8.27"(210)	CHG62150-061	116.84	7.28"(185)	7.48"(190)	24
		CHG62150-071	120.15	7.48"(190)	7.68"(195)	24
		CHG62150-081	121.25	7.68"(195)	7.87"(200)	24
		CHG62150-091	124.56	7.87"(200)	8.07"(205)	24
		CHG62150-101	127.87	8.07"(205)	8.27"(210)	24

Channel with 2 grates, water intake area 96.10 sq. ins

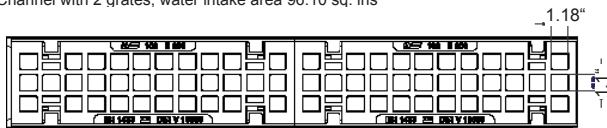

Water intake area 48.05 sq. ins

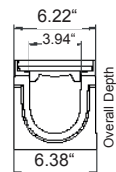
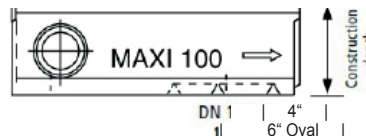
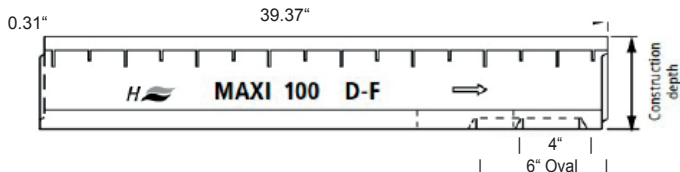
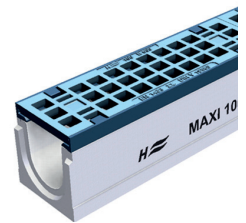
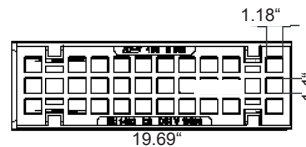

MAXI 150 SYSTEM (6")



MAXI 150 (6") with Ductile Iron ADA Load Class D & F Grate and Ductile Iron Frame

Product range

Part Description	Overall Depth Inches (mm)	Load Class D Part No.	Weight lbs	Load Class F Part No.	Weight lbs	Overall Depth Inches Inlet	Overall Depth (mm) Outlet	Pieces per pallet
Channel 39.37" (1m)	8.27" (210)	CHG61540-000	169.76	CHG61560-000	169.76	8.27"(210)	8.27"(210)	20
Channel 19.69" (0.5m)		CHG61540-005	80.47	CHG61560-005	84.66	8.27"(210)	8.27"(210)	30
Channel 19.69"(0.5m) with Side Opening		CHG61540-006	79.37	CHG61560-006	79.37	8.27"(210)	8.27"(210)	30
Channel 39.37" (1m)	10.23" (260)	CHG61540-050	185.19	CHG61560-050	185.19	10.23"(260)	10.23"(260)	20
Channel 19.69" (0.5m)		CHG61540-055	89.29	CHG61560-055	91.05	10.23"(260)	10.23"(260)	30
Channel 19.69"(0.5m) with Side Opening		CHG61540-056	88.18	CHG61560-056	88.18	10.23"(260)	10.23"(260)	30
Channel 39.37" (1m)	12.20" (310)	CHG61540-100	194.01	CHG61560-100	198.42	12.20"(310)	12.20"(310)	15
Channel 19.69" (0.5m)		CHG61540-105	98.11	CHG61560-105	99.21	12.20"(310)	12.20"(310)	30
Channel 19.69"(0.5m) with Side Opening		CHG61540-106	97.00	CHG61560-106	94.80	12.20"(310)	12.20"(310)	30
Catch Basin 19.69" (0.5m)	19.69" (500)	CHG61540-008	143.30	CHG61560-008	143.30	19.69"(500)	19.69"(500)	10
Channels with 1% Slope 39.37"(1m)	8.27" (210) - 10.24" (260)	CHG61540-011	164.24	CHG61560-011	173.28	8.27"(210)	8.66"(220)	20
		CHG61540-021	167.11	CHG61560-021	175.71	8.66"(220)	9.06"(230)	20
		CHG61540-031	170.64	CHG61560-031	179.68	9.06"(230)	9.45"(240)	20
		CHG61540-041	175.27	CHG61560-041	180.78	9.45"(240)	9.84"(250)	20
		CHG61540-051	176.37	CHG61560-051	182.98	9.84"(250)	10.23"(260)	20
Channels with 1% Slope 39.37"(1m)	10.24" (260) - 12.24" (310)	CHG61540-061	181.00	CHG61560-061	186.73	10.23"(260)	10.63"(270)	16
		CHG61540-071	182.54	CHG61560-071	194.67	10.63"(270)	11.02"(280)	16
		CHG61540-081	186.29	CHG61560-081	191.14	11.02"(280)	11.42"(290)	16
		CHG61540-091	188.94	CHG61560-091	198.20	11.42"(290)	11.81"(300)	16
		CHG61540-101	194.01	CHG61560-101	198.42	11.81"(300)	12.20"(310)	16

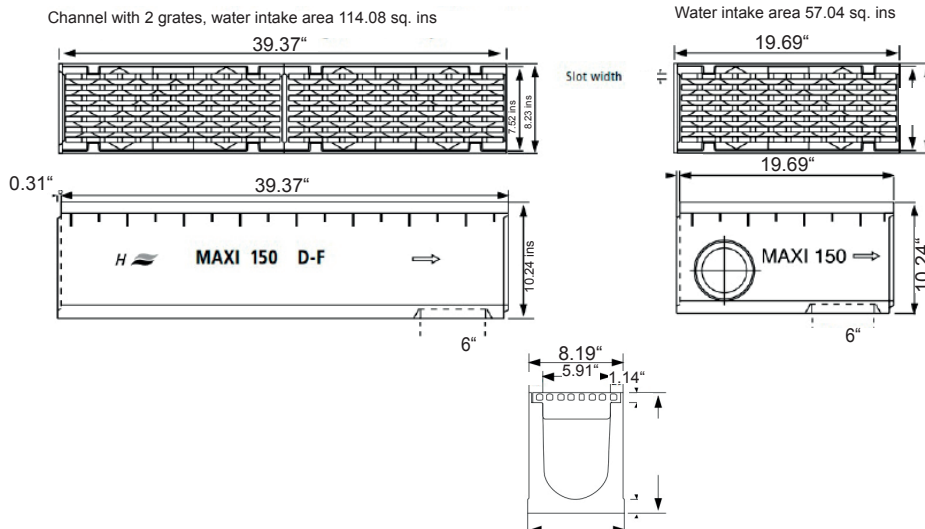

Ductile Iron grate with longitudinal slots

MAXI 150 SYSTEM (6")



MAXI 150 (6") with Ductile Iron Load Class E Grate and Ductile Iron Edge Rails

Product range

Part Description	Overall Depth Inches (mm)	Load Class E Part No.	Weight lbs	Overall Depth Inches (mm)		Pieces per pallet
				Inlet	Outlet	
Channel 39.37" (1m)	8.27" (210)	CHG62550-000	169.76	8.27"(210)	8.27"(210)	20
Channel 19.69" (0.5m)		CHG62550-005	80.47	8.27"(210)	8.27"(210)	30
Channel 19.69"(0.5m) with Side Opening		CHG62550-006	79.37	8.27"(210)	8.27"(210)	30
Channel 39.37" (1m)	10.23" (260)	CHG62550-050	185.19	10.23"(260)	10.23"(260)	20
Channel 19.69" (0.5m)		CHG62550-055	89.29	10.23"(260)	10.23"(260)	30
Channel 19.69"(0.5m) with Side Opening		CHG62550-056	88.18	10.23"(260)	10.23"(260)	30
Channel 39.37" (1m)	12.20" (310)	CHG62550-100	194.01	12.20"(310)	12.20"(310)	16
Channel 19.69" (0.5m)		CHG62550-105	98.11	12.20"(310)	12.20"(310)	30
Channel 19.69"(0.5m) with Side Opening		CHG62550-106	97.00	12.20"(310)	12.20"(310)	30
Catch Basin 19.69" (0.5m)	19.69" (500)	CHG62550-008	143.30	19.69"(500)	19.69"(500)	10
Channels with 1% Slope 39.37"(1m)	8.27"(210) - 10.24"(260)	CHG62550-011	164.24	8.27"(210)	8.66"(220)	20
		CHG62550-021	167.11	8.66"(220)	9.06"(230)	20
		CHG62550-031	170.64	9.06"(230)	9.45"(240)	20
		CHG62550-041	175.27	9.45"(240)	9.84"(250)	20
		CHG62550-051	176.37	9.84"(250)	10.23"(260)	20
Channels with 1% Slope 39.37"(1m)	10.24"(260) - 12.24"(310)	CHG62550-061	181.00	10.23"(260)	10.63"(270)	16
		CHG62550-071	182.54	10.63"(270)	11.02"(280)	16
		CHG62550-081	186.29	11.02"(280)	11.42"(290)	16
		CHG62550-091	188.94	11.42"(290)	11.81"(300)	16
		CHG62550-101	194.01	11.81"(300)	12.20"(310)	16



Ductile Iron grate with longitudinal slots

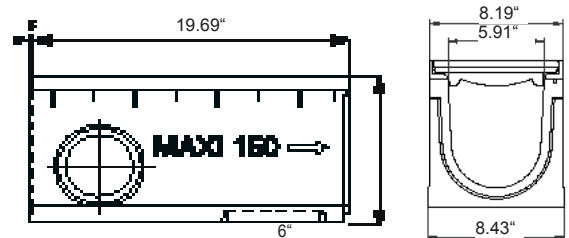
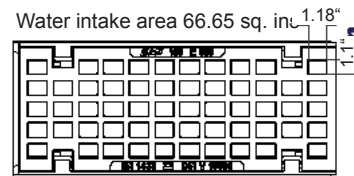
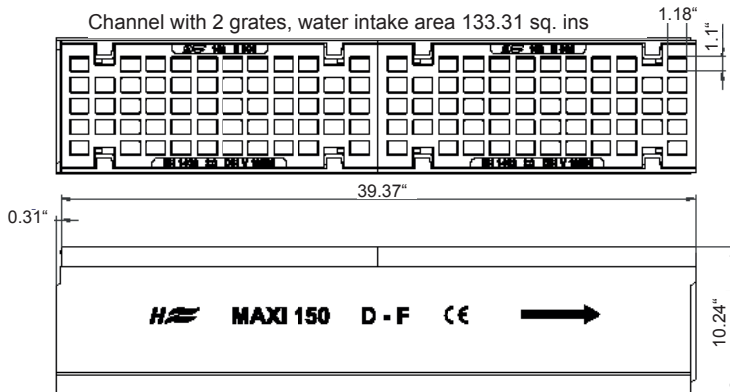

End Caps for all MAXI150

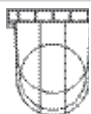

Open or Closed End Cap (Plastic) For All channels

Part.No.: CHG70011-51

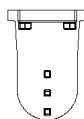

Closed End Cap (Iron)

Only for channels between 8.27" and 12.20" high

Part. No.: CHG70011-52

MAXI 200 SYSTEM (8")

MAXI 200 (8") with Ductile Iron ADA Load Class D & F Grate and Ductile Iron Frame



Product range

Part Description	Load Class D Part No.	Load Class F Part No.	Weight lbs	Overall Depth Inches (mm)		Pieces per pallet
				Inlet	Outlet	
Channel 39.37"(1m)	CHG61240-050	CHG61260-050	242.51	12.20"(310)	12.20"(310)	12
Channel 19.69"(0.5m)	CHG61240-055	CHG61260-055	121.25	12.20"(310)	12.20"(310)	24
Channel 19.69"(0.5m) with Side Opening	CHG61240-056	CHG61260-056	121.25	12.20"(310)	12.20"(310)	24
Catch Basin	CHG61240-008	CHG61260-008	158.73	21.65"(550)	21.65"(550)	6
Double Catch Basin	CHG61240-009	CHG61260-009	317.47	43.30"(1100)	43.30"(1100)	5

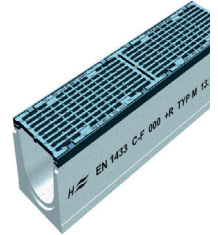

Ductile Iron grate

Channel with 2 grates, water intake area 150.35 sq. ins

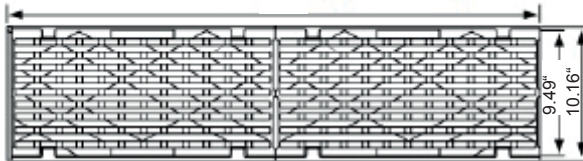

Water intake area 75.17 sq. ins

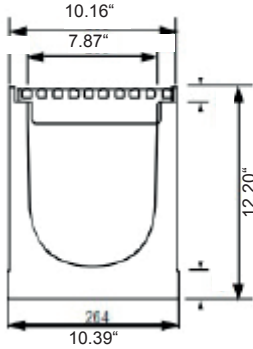
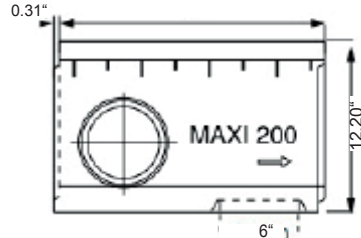
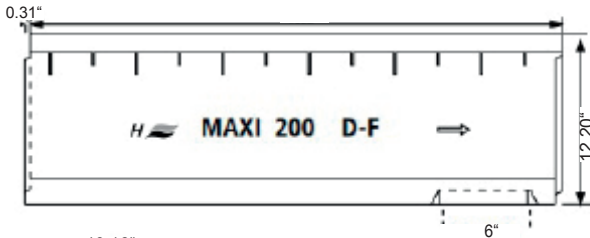
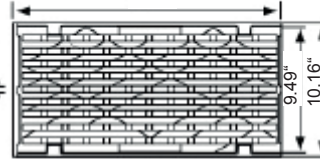

Accessories for MAXI 150 / 200

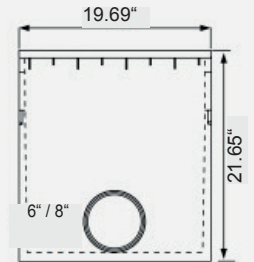

Catch Basin includes galvanized debris

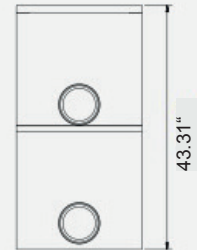

Double Catch Basin

End Caps for all MAXI200

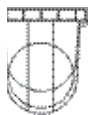

End Cap (Plastic)
Part.No.: CHG70012-00



6" Foul air stop
Part.No.: CHG70031-50

MAXI 200 SYSTEM (8")

MAXI 200 (8") with Ductile Iron Load Class E Grate and Ductile Iron Frame



Product range

Part Description	Load Class E Part No.	Weight lbs	Overall Inlet Inches	Overall Depth (mm) Outlet	Pieces per pallet
Channel 39.37"(1m)	CHG62250-050	234.79	12.20"(310)	12.20"(310)	12
Channel 19.69"(0.5m)	CHG62250-055	113.53	12.20"(310)	12.20"(310)	24
Channel 19.69"(0.5m) with Side Opening	CHG62250-056	113.53	12.20"(310)	12.20"(310)	24
Catch Basin	CHG62250-008	151.01	21.65"(550)	21.65"(550)	6
Double Catch Basin	CHG62250-009	317.47	43.30"(1100)	43.30"(1100)	5



Ductile Iron grate

Channel with 2 grates, water intake area 161.21 sq. ins

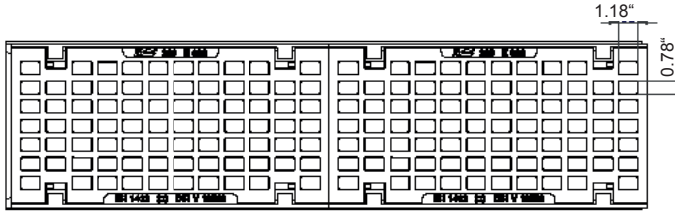

Water intake area 80.60 sq. ins

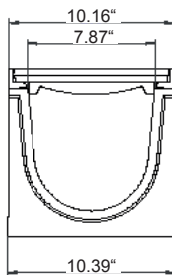
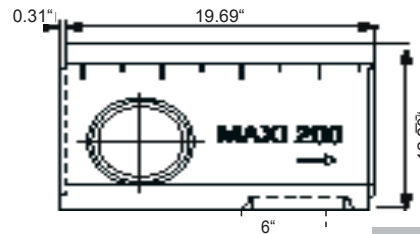
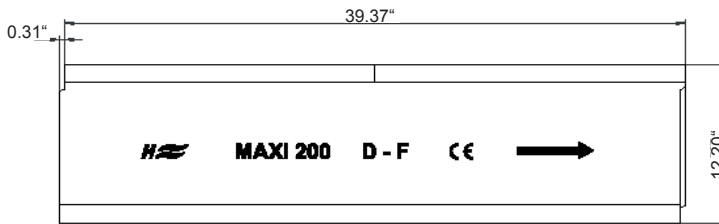
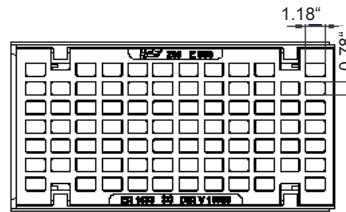

Accessories for MAXI 150/200

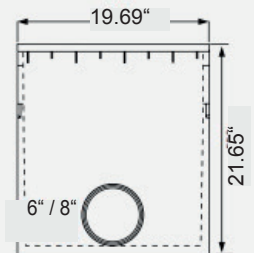

Catch Basin includes galvanized debris basket

End Caps for all MAXI200

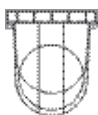

End Cap (Plastic)
Part.No.: CHG70012-00



6" Foul air stop
Part.No.: CHG70031-50

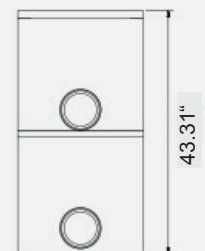

Double Catch Basin

SPECIAL APPLICATIONS

System MAXI F1 – High Security Trench Drain

The trench drain system for applications with extremely demanding security requirements.

The absorption of maximum undertow and brake forces in combination with sufficient fire resistance are the requirements for pre-fabricated parts in areas with extreme traffic loads. Longitudinal slots prevent overflowing water and allow the absorption of twice the amount of water.

A special screw locking system with the benefits of stainless steel screws:

- Easy to maintain, only 2 instead of 4 screws per grating centrally arranged, no contamination at the screw recess, resilient to corrosion
- Through-screw-thread with self cleaning system threaded blind holes for screw connections at edges

The combination of material and design benefits was the precondition for fulfilling the demanding security requirements at the Formula 1 circuits in Shanghai and Istanbul and led to the MAXI F1 being selected along with cost-efficiency considerations.

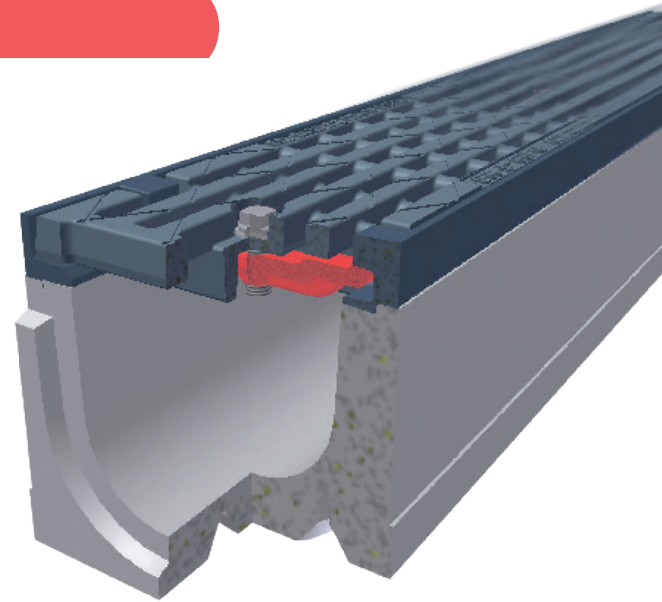

Istanbul



Shanghai



F1 - Shanghai Racing Circuit

F1 Locking Available for MAXI 100 (4") / 150 (6") / 200 (8") / 300 (12")

Length: 39.37" (1meter)

Inner width: 4"(100 mm) / 6"(150 mm) / 8"(200 mm) / 12"(300 mm)

Inlet diameter: 79.36 / 114.08 / 150.35 / 173.6 sq. ins

MAXI F1 100 (4") / 150 (6") / 200 (8") Load Class F

MAXI F1 300 (12") Load Class E & F

Complete with a channel base of fiber-reinforced, frost and de-icing salt resilient concrete C35 / 45 with ductile iron edge protection anchored throughout

- 8 interlocking points per meter (39.37")
- 2 gratings made of ductile iron with longitudinal slots (0.47 ins interspace)
- Traffic safe special screw locking system of the cover gratings
- 4 custom screws per meter and 8 interlocking points per meter
- CE compliant
- Secure anchoring prevents "outgrowing"
- Prefabricated parts for easy assembling of the sections
- Secure rebated joint for optional sealing in line with "WHSG"
- Pre-cast base for vertical 4" and 6" pipe connection

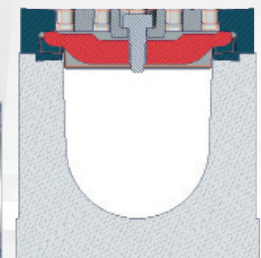
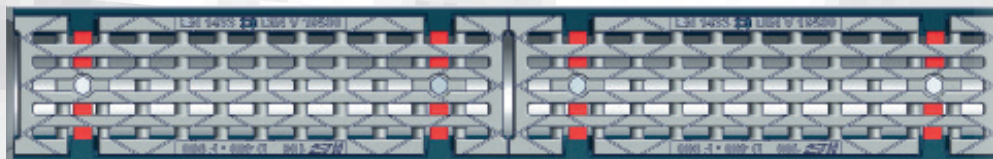

MAXI "F1" SYSTEM 300 (12")

Product Description

The MAXI 300 (12") is available with the "F1" locking system, which was developed for Formula 1 race circuits and meets the most rigorous requirements in high security areas.



- Load Class E and F
- High security "F1" locking system
- For areas with extremely high wheel loads e.g. harbor facilities
- 12" Wide
- Flat 39.37" (1 meter) or 19.69" (0.5 meters) long

Hllster-Berg Circuit, Germany



Fig.: locking device

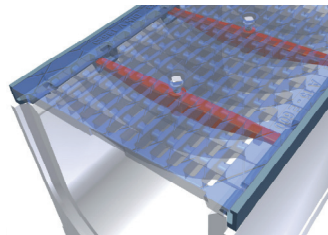

Areas of application

- Industrial areas with heavy goods traffic
- Car parks for heavy goods vehicles
- Loading and unloading areas
- Race Circuits

MAXI 300 (12") SYSTEM

MAXI 300 (12") with Ductile Iron ADA Load Class E & F Grate and Ductile Iron Edge Rails



Product range

Part Description	Load Class E Part No.	Weight lbs	Load Class F Part No.	Weight lbs	Overall Depth Inches (mm) Inlet Outlet	Pieces per pallet
Channel 39.37"(1m)	CHG66350-0501	396.83	CHG66360-0501	436.51	15.75(400)	6
Channel 19.69"(0.5m)	CHG66350-0551	198.41	CHG66360-0551	202.82	15.75(400)	4
Catch Basin	CHG66350-0081	306.44	CHG66360-0081	306.44	29.53(750)	4

The MAXI 300 does not have a precast outlet underneath. However, channels with drilled holes underneath to create the outlet are available (Load Class E: Part No. CHG66350-0571 & Load Class F: Part No. CHG66360-0571)



Channel with 2 grates, water intake area 173.60 sq. ins

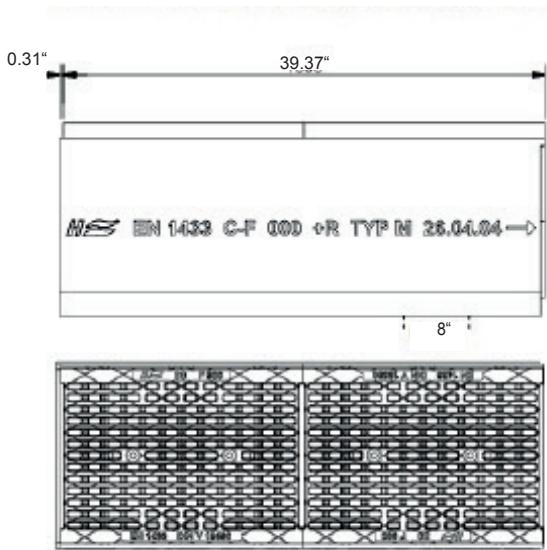

Water Intake area 86.80 sq. ins

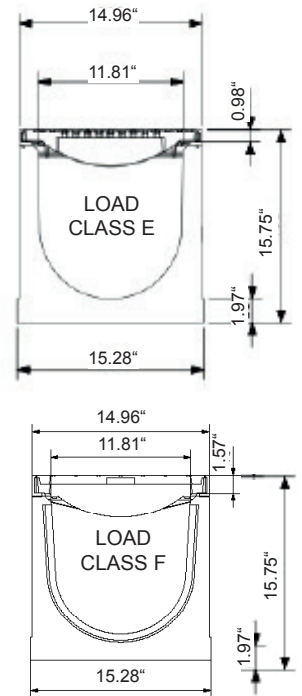

Accessories

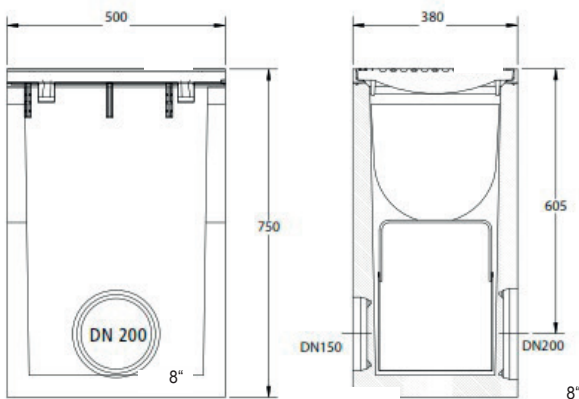

Catch Basin includes galvanized dirt catcher

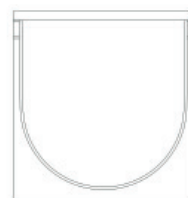

Closed End Cap Iron (CHG70031-11)

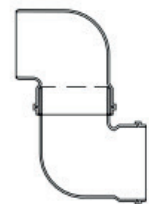

8" Foul air stop
Part.No.:
CHG70032-00

HYDROline

HYDROline

HYDROline is a flat drainage channel made on one ductile iron piece. Very easy to install as it sits directly on top of the concrete.

Application areas:

- Indoor and outdoor areas
- Indoor car parks, underground garages, parking decks, terraces, industrial plants etc.
- Pedestrian areas
- Areas with low rainfall



Part. No. CHG68000-000 26.45 lbs

Properties:

- Low concrete bed
- Ease of installation
- Extremely resistant
- Easy cleaning
- One piece = rattle free
- Fixes to the concrete bed thanks to built in anchors underneath

Description / sizes:

- Standard part approx. 4.72"(120mm) x 39.37"(1000mm)
- Part with outlet approx. 4.72"(120mm) x 39.37"(1000mm)
- Height without anchors approx. 1.18" (30mm)
- Load Class F 900kN (202,320 lbs)
- Ductile Iron

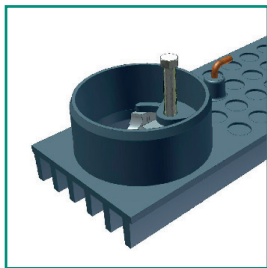

Security of grate due to bar = protection against anti-theft and vandalism

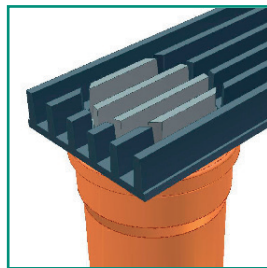

Channel with vertical outlet for 4" pipe

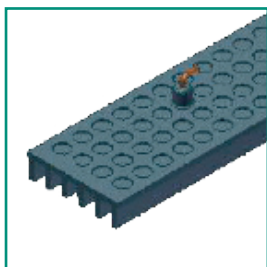

Anchors underneath help secure the channel to the concrete

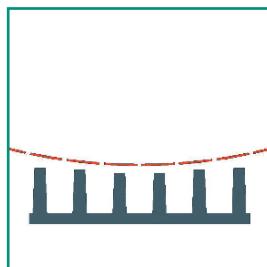

Concave shape prevents overflow

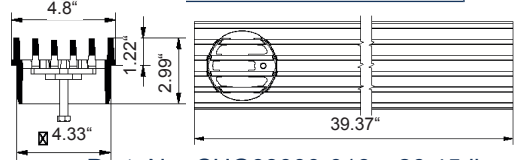
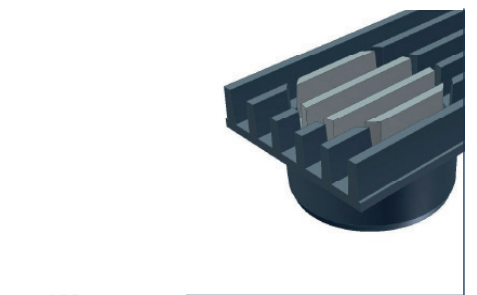

Part. No. CHG68000-018 26.45 lbs

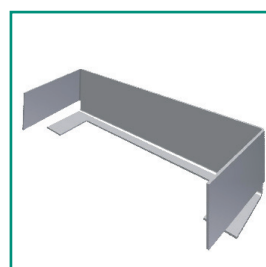

End wall piece available
Part No. CHG68001-700

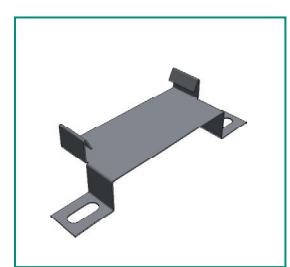

Installation Support
Part No. CHG68001-701

HYDROblock SYSTEM 100 (4'') / 200 (8'') / 300 (12'')

One Piece Ductile Iron Trench Drain. Simple. Safe.

One piece trench drain system where the channel and the grate are casted together out of ductile iron. Available in 4'', 8'' and 12'' wide.

This revolutionary, new, monolithic drainage channel system sets new standards in drainage technology.

Handling is substantially improved by the innovative seal system which enables the completion of water-tight, maintenance-free drainage channel lines with very little effort. Tried and trusted seal types used for standard plastic piping are deployed here. The pipe joint and spigot end version ensures easy handling and foolproof installation. The special elements available include both horizontal and vertical connectors.

The HYDROblock system is a type "I" channel type in line with EN 1433 standard and thus does not require additional concrete encasement. It simply requires a load-bearing foundation with installation shoring. This reduces the installation time considerably and means that the channel can be fully loaded immediately after installation.

The one piece design guarantees rattle-free operations and long-lasting traffic safety, especially in traffic areas with extreme loads, such as container terminals, truck loading zones and airports.

- Minimal planning and installation requirement
- Low maintenance
- Theft and vandalism protection
- Best of class frost and de-icing salt resilience
- One piece design made of ductile iron
- Up to 50% greater run-in diameter compared with similar systems
- 4'', 8'' & 12''

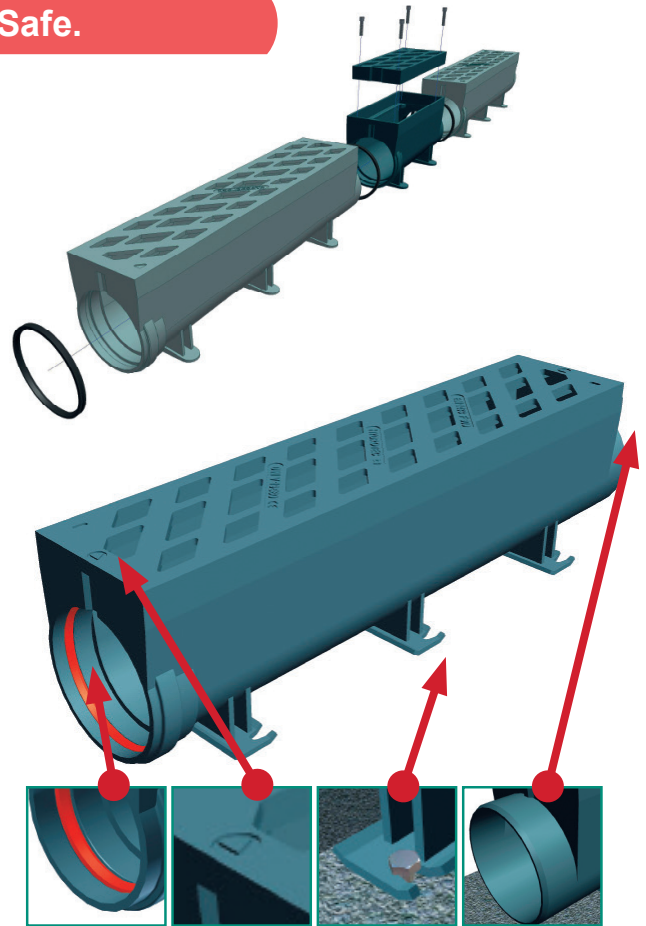

The first channel with sealing ring

Labeling of the flow direction

Pedestals for optional foundation installation

Long spigot end guarantees a reliable seal

Areas of application

- Areas that require long-term traffic safety
- Installation at right angles to the road surface
- Container terminals
- Industrial areas with heavy traffic loads
- Airports and race circuits

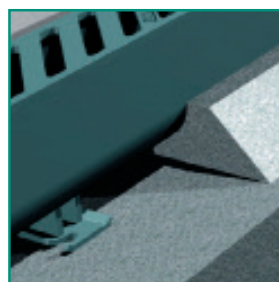

Type I channel without additional concrete encasement

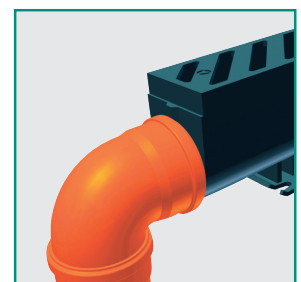

Joints with standard plastic pipes

HYDROblock SYSTEM

HYDROblock 100 (4") / 200 (8") / 300 (12") Load Class F



Part Description	Part No.	Weight lbs	Overall Depth Inches (mm)	Pieces per pallet
HYDROblock 100 (4")				
39.37" (1m)	CHG60060-050	55.12	7.09"(180)	40
19.69"(0.5m) With Outlet(s):				
1 Outlet: Vertical	CHG60060-058	37.48	7.09"(180)	
2 Outlets: left & right	CHG60060-358	37.48	7.09"(180)	
3 Outlets: face side&left & right	CHG60060-458	39.68	7.09"(180)	
Catch Basin 19.69" (0.5m)				
with 4" outlet	CHG60060-008	74.96	19.69"(500)	
HYDROblock 200 (8")				
39.37" (1m)	CHG60260-050	145.51	11.61"(295)	20
19.69"(0.5m) With Outlet(s):				
1 Outlet: Vertical	CHG60260-058	92.59	11.61"(295)	
2 Outlets: left & right	CHG60260-358	92.59	11.61"(295)	
Catch Basin 19.69" (0.5m)				
with 8" outlet	CHG60260-008	132.28	19.69"(500)	
HYDROblock 300 (12")				
39.37" (1m)	CHG60360-050	242.51	16.26"(413)	20
19.69"(0.5m) With Outlet(s):				
1 Outlet: Vertical	CHG60360-058	231.48	16.26"(413)	
2 Outlets: left & right	CHG60360-358	234.79	16.26"(413)	

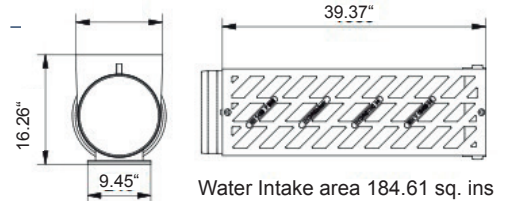
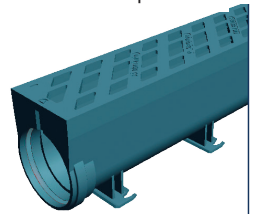
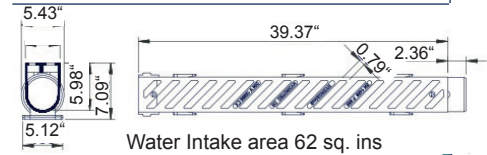
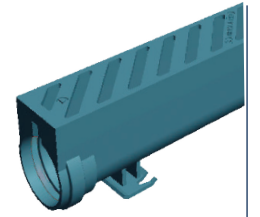

Parts with Outlets

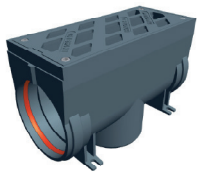

Vertical outlet with 1 pipe socket

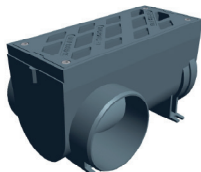

Outlet right & left with 2 pipe sockets



Outlet face side & right & left with 3 pipe sockets

Catch Basins

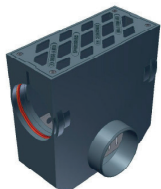

View from left

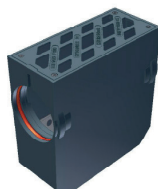

View from right

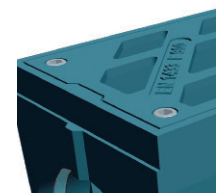

4x screw connection for noise-free seating and safe access for inspection work.



Maintenance free type with open, downward facing screw holes.

Accessories for HYDROblock

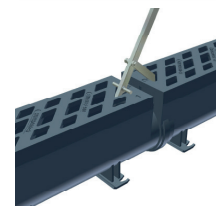

Easy laying with laying tool



Fully compatible with standard PE and PP pipes



Quality – Service – Commitment – Delivered.

www.sigmaco.com

SPECIFICATIONS



HYDROTEC 

Technologies

Rev 4/30/15

Specifications

MAXI100

4" [100] WIDE THROAT TRENCH DRAIN SYSTEM WITH DUCTILE IRON FRAME

Dimensional Data (inches and [mm]) are Subject to Manufacturing Tolerances and Change Without Notice

ENGINEERING SPECIFICATION: HYDROTEC MAXI100 Channels shall be 39.37" [1000] long, 6.22" [158] wide reveal and have a 3.94" [100] wide throat. Modular channel sections shall be made of fiber-reinforced concrete C35/45. Shall have a male/female connection between channel sections that will not separate during the installation. Channels shall have a radiused self-cleaning bottom and 0.5% or neutral 0% built in slope. Channels shall have Ductile Iron Edge Rails built into the fiber-reinforced concrete. Channels shall have all grates locked down as per HYDROTEC's patented locking mechanism whereby the polyamide rod is pushed and locked underneath the grate.

MAXI 3.94" [100] wide throat **Ductile Iron ADA Grate is rated class C** per the DIN EN1433 top load classifications. Ductile Iron conforms to ASTM specification A536-84, Grade 80-55-06. Supplied in 39.37" [1000] or 19.69" [500] nominal lengths with 4.72/0.55 [120/14] wide slots. Grate has an open area of 26.08 sq. in per ft. [55206 sq.mm per meter].

MAXI 3.94" [100] wide throat **Ductile Iron ADA Grate is rated class D** per the DIN EN1433 top load classifications. Ductile Iron conforms to ASTM specification A536-84, Grade 80-55-06. Supplied in 39.37" [1000] or 19.69" [500] nominal lengths with 1.02/0.47 [26/12] wide slots. Grate has an open area of 24.18 sq. in per ft. [51200 sq.mm per meter].

MAXI 3.94" [100] wide throat **Ductile Iron Mesh Grate is rated class E** per the DIN EN1433 top load classifications. Ductile Iron conforms to ASTM specification A536-84, Grade 80-55-06. Supplied in 39.37" [1000] or 19.69" [500] nominal lengths with 1.18/1.1 [29.9/27.4] wide slots. Grate has an open area of 29.29 sq. in per ft. [62000 sq.mm per meter].

MAXI 3.94" [100] wide throat **Ductile Iron ADA Grate is rated class F** per the DIN EN1433 top load classifications. Ductile Iron conforms to ASTM specification A536-84, Grade 80-55-06. Supplied in 39.37" [1000] or 19.69" [500] nominal lengths with 1.02/0.47 [26/12] wide slots. Grate has an open area of 24.18 sq. in per ft. [51200 sq.mm per meter].

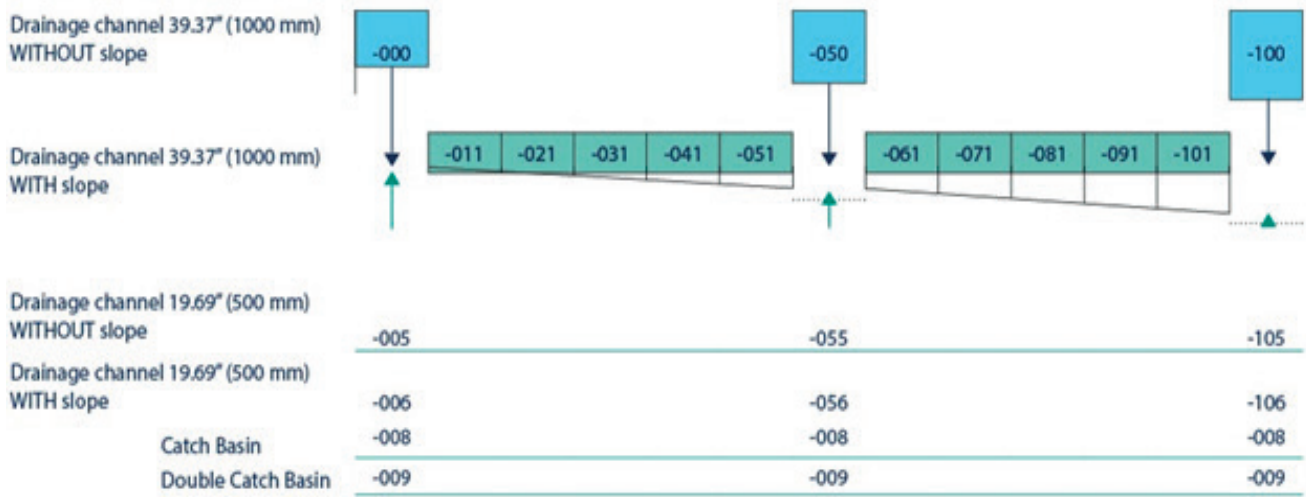

Specifications

MAXI100 Parts Guide

Product Description	With Ductile Iron ADA Class C Grate Part No.	Weight Lbs	With Ductile Iron ADA Class D Grate Part No.	Weight Lbs	With Ductile Iron Mesh Class E Grate Part No.	Weight Lbs	With Ductile Iron ADA Class F Grate Part No.	Weight Lbs	'A' Shallow Invert Inches [mm]	'B' Shallow Invert Inches [mm]
Neutral Channel 39.37" (1m)	CHG61131-000	99.21	CHG61140-000	112.44	CHG62150-000	112.44	CHG61160-000	112.44	6.30"[160]	6.30"[160]
Neutral Channel 19.69" (0.5m)	CHG61131-005	54.01	CHG61140-005	51.81	CHG62150-005	51.81	CHG61160-005	51.81	6.30"[160]	6.30"[160]
M1 Sloped Channel 39.37" (1m)	CHG61131-011	98.11	CHG61140-011	106.92	CHG62150-011	106.92	CHG61160-011	113.54	6.30"[160]	6.50"[165]
M2 Sloped Channel 39.37" (1m)	CHG61131-021	98.11	CHG61140-021	109.13	CHG62150-021	109.13	CHG61160-021	115.74	6.50"[165]	6.69"[170]
M3 Sloped Channel 39.37" (1m)	CHG61131-031	98.11	CHG61140-031	111.33	CHG62150-031	111.33	CHG61160-031	117.95	6.69"[170]	6.89"[175]
M4 Sloped Channel 39.37" (1m)	CHG61131-041	99.21	CHG61140-041	112.44	CHG62150-041	112.44	CHG61160-041	120.15	6.89"[175]	7.09"[180]
M5 Sloped Channel 39.37" (1m)	CHG61131-051	101.41	CHG61140-051	114.64	CHG62150-051	114.64	CHG61160-051	122.36	7.09"[180]	7.28"[185]
Neutral Channel 39.37" (1m)	CHG61131-050	108.03	CHG61140-050	122.36	CHG62150-050	122.36	CHG61160-050	122.36	7.28"[185]	7.28"[185]
Neutral Channel 19.69" (0.5m)	CHG61131-055	51.81	CHG61140-055	58.42	CHG62150-055	58.42	CHG61160-055	58.42	7.28"[185]	7.28"[185]
M6 Sloped Channel 39.37" (1m)	CHG61131-061	103.62	CHG61140-061	116.84	CHG62150-061	116.84	CHG61160-061	124.56	7.28"[185]	7.48"[190]
M7 Sloped Channel 39.37" (1m)	CHG61131-071	106.92	CHG61140-071	120.15	CHG62150-071	120.15	CHG61160-071	126.77	7.48"[190]	7.68"[195]
M8 Sloped Channel 39.37" (1m)	CHG61131-081	108.03	CHG61140-081	121.25	CHG62150-081	121.25	CHG61160-081	128.97	7.68"[195]	7.87"[200]
M9 Sloped Channel 39.37" (1m)	CHG61131-091	111.33	CHG61140-091	124.56	CHG62150-091	124.56	CHG61160-091	131.18	7.87"[200]	8.07"[205]
M10 Sloped Channel 39.37" (1m)	CHG61131-101	114.64	CHG61140-101	127.87	CHG62150-101	127.87	CHG61160-101	133.38	8.07"[205]	8.27"[210]
Neutral Channel 39.37" (1m)	CHG61131-100	119.05	CHG61140-100	133.38	CHG62150-100	133.38	CHG61160-100	133.38	8.27"[210]	8.27"[210]
Neutral Channel 19.69" (0.5m)	CHG61131-105	54.01	CHG61140-105	49.60	CHG62150-105	59.52	CHG61160-105	49.60	8.27"[210]	8.27"[210]
Neutral Channel 39.37" (1m)	NA	NA	CHG61140-150	137.79	CHG62150-150	137.79	CHG61160-150	137.79	9.25"[235]	9.25"[235]
Neutral Channel 19.69" (0.5m)	NA	NA	CHG61140-155	68.34	CHG62150-155	68.34	CHG61160-155	68.34	9.25"[235]	9.25"[235]
Neutral Channel 39.37" (1m)	NA	NA	CHG61140-200	143.30	CHG62150-200	143.30	CHG61160-200	143.30	10.23"[260]	10.23"[260]
Neutral Channel 19.69" (0.5m)	NA	NA	CHG61140-205	71.65	CHG62150-205	71.65	CHG61160-205	71.65	10.23"[260]	10.23"[260]
Catch Basin 19.69" (0.5m)	CHG61131-008	109.13	CHG61140-008	114.64	CHG62150-008	114.64	CHG61160-008	114.64	19.69"[500]	19.69"[500]

ACCESSORIES MAXI100	Part No.
Closed End Cap for All MAXI100 (2 Parts: Plastic Support + Galvanized Steel Cap)	CHG70011-10
Closed End Cap for 6.30" MAXI100 (1 Iron Part)	CHG70011-11
Closed End Cap for 7.28" MAXI100 (1 Iron Part)	CHG70011-12
Open End Cap for All MAXI100 with Connection to 4" Pipe (2 Parts: Plastic Support + Galvanized Steel Cap)	CHG70011-20
4" Pipe Connection (PVC) for all MAXI100	CHG70021-00
6" Pipe Connection (PVC) for all MAXI100	CHG70021-60

Specifications

MAXI100 with Ductile Iron ADA Load Class C (Part No. CHG61131-*)

Channel with 2 grates, water intake area 85.87 sq. ins

Water Intake area 42.93 sq. ins.

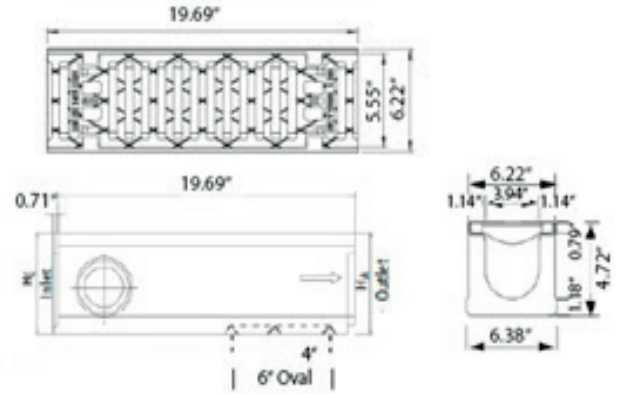
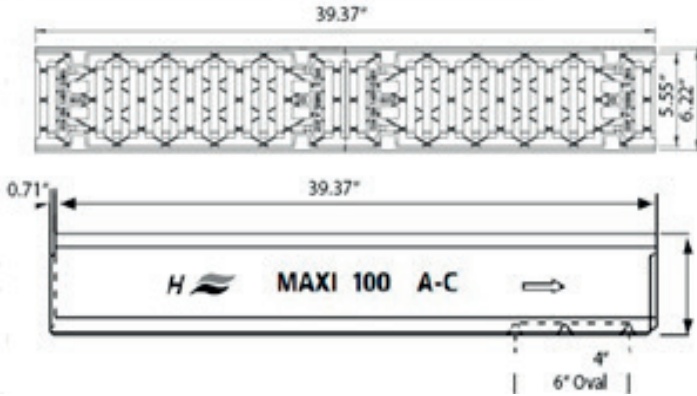

MAXI100 with Ductile Iron ADA Load Class D (Part No. CHG61140-*) and ADA Load Class F (Part No. CHG61160-*)

Channel with 2 grates, water intake area 79.36 sq. ins

Water intake area 39.68 sq. ins

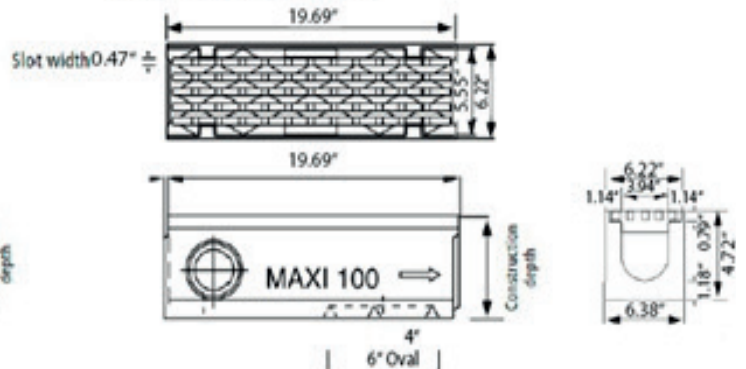
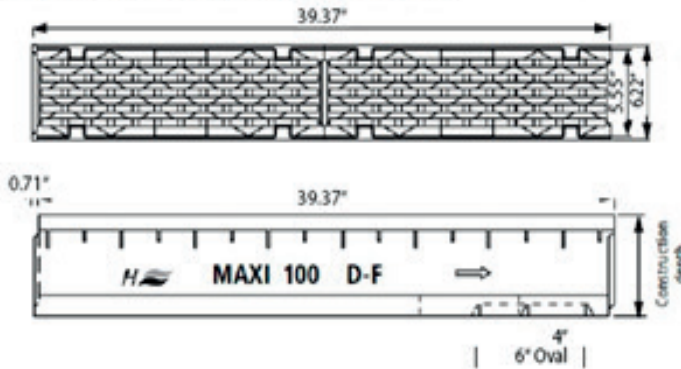

MAXI100 with Ductile Iron Class E Grate: Part No. CHG62150-*

Channel with 2 grates, water intake area 96.10 sq. ins

Water intake area 48.05 sq. ins

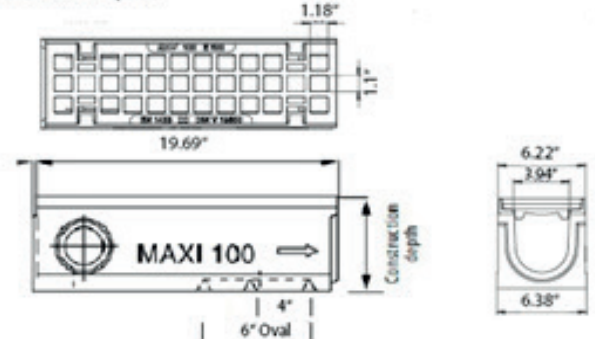
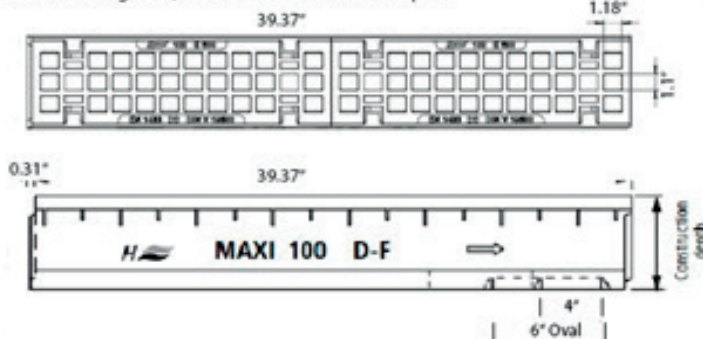

Catch Basin and End Caps for All MAXI100

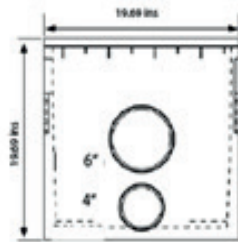

Catch Basin
incl. galvanized dirt
catcher



Closed End Piece
Part.No.:
CHG70011-10



Open End Piece with 4"
Pipe Connection
Part.No.: CHG70011-20

Supplied By:

**TRENCHDRAIN
SUPPLY**

877-903-7246

www.trenchdrainsupply.com

Specifications

MAXI150

6" [150] WIDE THROAT TRENCH DRAIN SYSTEM WITH DUCTILE IRON FRAME

Dimensional Data (inches and [mm]) are Subject to Manufacturing Tolerances and Change Without Notice

ENGINEERING SPECIFICATION: HYDROTEC MAXI150 Channels shall be 39.37" [1000] long, 8.19" [208] wide reveal and have a 5.91" [150] wide throat. Modular channel sections shall be made of fiber-reinforced concrete C35/45. Shall have a male/female connection between channel sections that will not separate during the installation. Channels shall have a radiused self-cleaning bottom and 1% or neutral 0% built in slope. Channels shall have Ductile Iron Edge Rails built into the fiber-reinforced concrete. Channels shall have all grates locked down as per HYDROTEC's patented locking mechanism whereby the polyamide rod is pushed and locked underneath the grate.

MAXI 5.91" [150] wide throat **Ductile Iron ADA Grate is rated class D** per the DIN EN1433 top load classifications. Ductile Iron conforms to ASTM specification A536-84, Grade 80-55-06. Supplied in 39.37" [1000] or 19.69" [500] nominal lengths with 0.94/0.47 [24/12] wide slots. Grate has an open area of 34.77 sq. in per ft. [73,600 sq.mm per meter].

MAXI 5.91" [150] wide throat **Ductile Iron ADA Grate is rated class E** per the DIN EN1433 top load classifications. Ductile Iron conforms to ASTM specification A536-84, Grade 80-55-06. Supplied in 39.37" [1000] or 19.69" [500] nominal lengths with 1.18/1.1 [30/23] wide slots. Grate has an open area of 40.63 sq. in per ft. [86,006 sq.mm per meter].

MAXI 5.91" [150] wide throat **Ductile Iron ADA Grate is rated class F** per the DIN EN1433 top load classifications. Ductile Iron conforms to ASTM specification A536-84, Grade 80-55-06. Supplied in 39.37" [1000] or 19.69" [500] nominal lengths with 0.94/0.47 [24/12] wide slots. Grate has an open area of 34.77 sq. in per ft. [73,600 sq.mm per meter].

Guide to Pre-Sloped Modular System

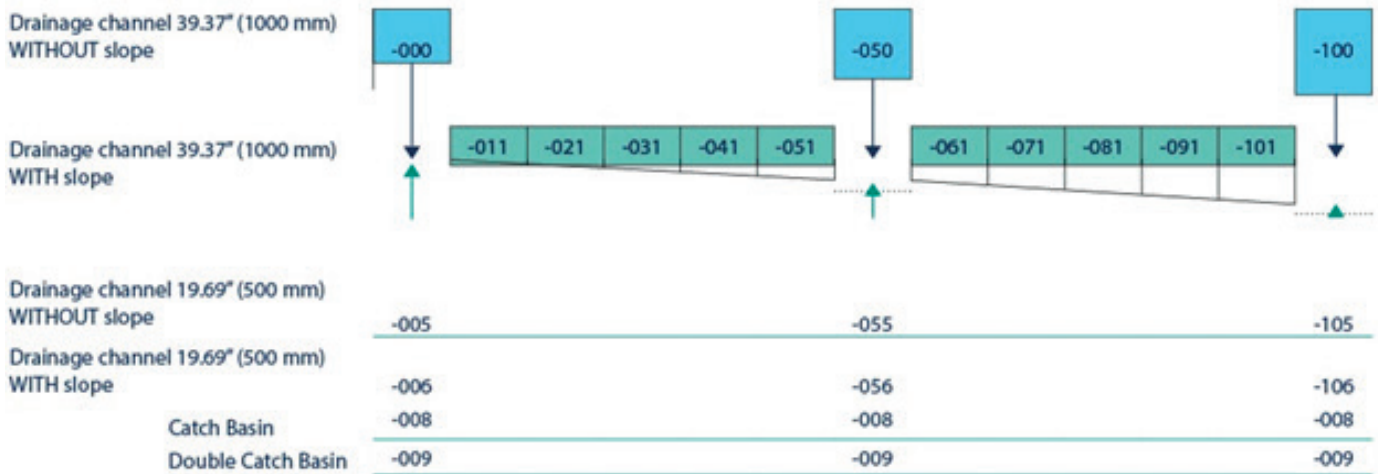

Specifications

MAXI150 Parts Guide

Product Description	With Ductile Iron ADA Class D Grate Part No.	Weight Lbs	With Ductile Iron ADA Class E Grate Part No.	Weight Lbs	With Ductile Iron Mesh Class F Grate Part No.	Weight Lbs	'A' Shallow Invert Inches [mm]	'B' Shallow Invert Inches [mm]
Neutral Channel 39.37" (1m)	CHG61540-000	169.76	CHG62550-000	169.76	CHG61560-000	169.76	8.27"[210]	8.27"[210]
Neutral Channel 19.69" (0.5m)	CHG61540-005	80.47	CHG62550-005	80.47	CHG61560-005	84.66	8.27"[210]	8.27"[210]
M1 Sloped Channel 39.37" (1m)	CHG61540-011	164.24	CHG62550-011	164.24	CHG61560-011	173.28	8.27"[210]	8.66"[220]
M2 Sloped Channel 39.37" (1m)	CHG61540-021	167.11	CHG62550-021	167.11	CHG61560-021	175.71	8.66"[220]	9.06"[230]
M3 Sloped Channel 39.37" (1m)	CHG61540-031	170.64	CHG62550-031	170.64	CHG61560-031	179.68	9.06"[230]	9.45"[240]
M4 Sloped Channel 39.37" (1m)	CHG61540-041	175.27	CHG62550-041	175.27	CHG61560-041	180.78	9.45"[240]	9.84"[250]
M5 Sloped Channel 39.37" (1m)	CHG61540-051	176.37	CHG62550-051	176.37	CHG61560-051	182.98	9.84"[250]	10.23"[260]
Neutral Channel 39.37" (1m)	CHG61540-050	185.19	CHG62550-050	185.19	CHG61560-050	185.19	10.23"[260]	10.23"[260]
Neutral Channel 19.69" (0.5m)	CHG61540-055	89.29	CHG62550-055	89.29	CHG61560-055	91.05	10.23"[260]	10.23"[260]
M6 Sloped Channel 39.37" (1m)	CHG61540-061	181.00	CHG62550-061	181.00	CHG61560-061	186.73	10.23"[260]	10.63"[270]
M7 Sloped Channel 39.37" (1m)	CHG61540-071	182.54	CHG62550-071	182.54	CHG61560-071	194.67	10.63"[270]	11.02"[280]
M8 Sloped Channel 39.37" (1m)	CHG61540-081	186.29	CHG62550-081	186.29	CHG61560-081	191.14	11.02"[280]	11.42"[290]
M9 Sloped Channel 39.37" (1m)	CHG61540-091	188.94	CHG62550-091	188.94	CHG61560-091	198.20	11.42"[290]	11.81"[300]
M10 Sloped Channel 39.37" (1m)	CHG61540-101	194.01	CHG62550-101	194.01	CHG61560-101	198.42	11.81"[300]	12.20"[310]
Neutral Channel 39.37" (1m)	CHG61540-100	194.01	CHG62550-100	194.01	CHG61560-100	198.42	12.20"[310]	12.20"[310]
Neutral Channel 19.69" (0.5m)	CHG61540-105	98.11	CHG62550-105	98.11	CHG61560-105	99.21	12.20"[310]	12.20"[310]
Catch Basin 19.69" (0.5m)	CHG61540-008	143.30	CHG62550-008	143.30	CHG61560-008	143.30	19.69"[500]	19.69"[500]

ACCESSORIES MAXI150	Part No.
End Cap for MAXI150 (Open & Closed): 1 plastic part to close MAXI150 trench drains of all depths that can be cut to connect 6" pipes	CHG70011-51
6" Pipe Connection (PVC) for all MAXI150	CHG70021-50

Specifications

MAXI150 with Ductile Iron ADA Load Class D (Part No. CHG61540-*) and ADA Load Class F (Part No. CHG61560-*)

Channel with 2 grates, water intake area 114.08 sq. ins

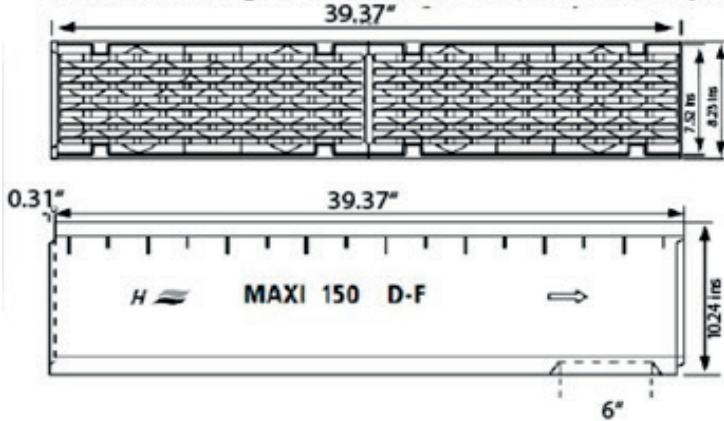

Water intake area 57.04 sq. ins

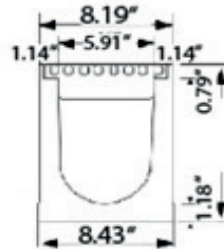
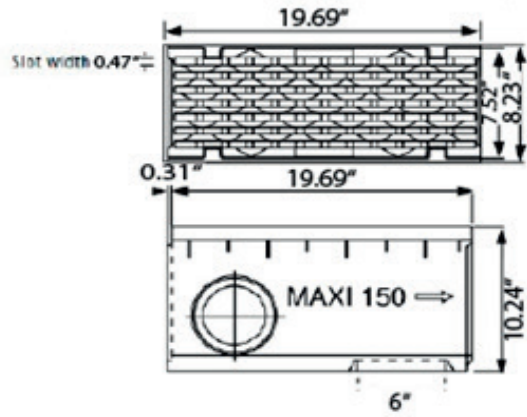

MAXI150 with Ductile Iron Class E Grate: Part No. CHG62550-*

Channel with 2 grates, water intake area 133.31 sq. ins

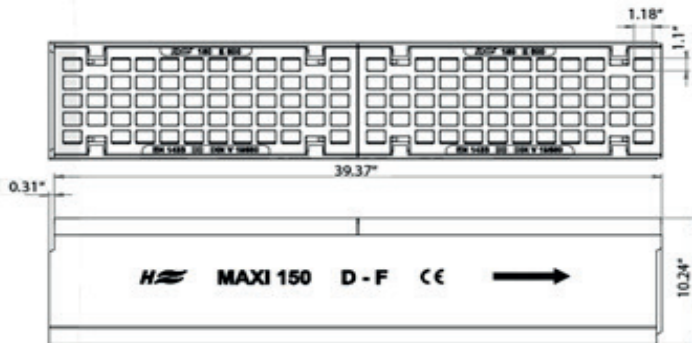

Water intake area 66.65 sq. ins

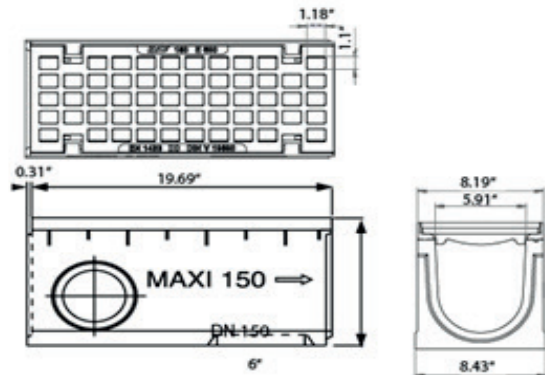

Catch Basin and End Caps for All MAXI150

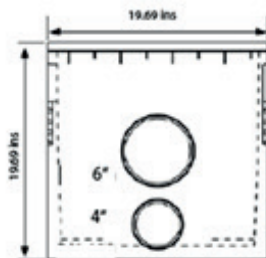

Open or Closed End Cap (Plastic)
For All channels
Part.No.: CHG70011-51

Catch Basin
incl. galvanized dirt
catcher

Specifications

MAXI200

8" [200] WIDE THROAT TRENCH DRAIN SYSTEM WITH DUCTILE IRON FRAME

Dimensional Data (inches and [mm]) are Subject to Manufacturing Tolerances and Change Without Notice

ENGINEERING SPECIFICATION: HYDROTEC MAXI200 Channels shall be 39.37" [1000] long, 10.16" [258] wide reveal and have a 7.87" [200] wide throat. Modular channel sections shall be made of fiber-reinforced concrete C35/45. Shall have a male/female connection between channel sections that will not separate during the installation. Channels shall have a radiused self-cleaning bottom and neutral 0% built in slope. Channels shall have Ductile Iron Edge Rails built into the fiber-reinforced concrete. Channels shall have all grates locked down as per HYDROTEC's patented locking mechanism whereby the polyamide rod is pushed and locked underneath the grate.

MAXI 7.87" [200] wide throat **Ductile Iron ADA Grate is rated class D** per the DIN EN1433 top load classifications. Ductile Iron conforms to ASTM specification A536-84, Grade 80-55-06. Supplied in 39.37" [1000] or 19.69" [500] nominal lengths with 0.86/0.47 [24/12] wide slots. Grate has an open area of 45.82 sq. in per ft. [97,000 sq.mm per meter].

MAXI 7.87" [200] wide throat **Ductile Iron Grate is rated class E** per the DIN EN1433 top load classifications. Ductile Iron conforms to ASTM specification A536-84, Grade 80-55-06. Supplied in 39.37" [1000] or 19.69" [500] nominal lengths with 1.18/0.78 [30/20] wide slots. Grate has an open area of 49.13 sq. in per ft. [104,006 sq.mm per meter].

MAXI 7.87" [200] wide throat **Ductile Iron ADA Grate is rated class F** per the DIN EN1433 top load classifications. Ductile Iron conforms to ASTM specification A536-84, Grade 80-55-06. Supplied in 39.37" [1000] or 19.69" [500] nominal lengths with 1.02/0.47 [26/12] wide slots. Grate has an open area of 45.82 sq. in per ft. [97,000 sq.mm per meter].

MAXI200 Parts Guide

Product Description	With Ductile Iron ADA Class D Grate Part No.	Weight Lbs	With Ductile Iron ADA Class E Grate Part No.	Weight Lbs	With Ductile Iron Mesh Class F Grate Part No.	Weight Lbs	'A' Shallow Invert Inches [mm]	'B' Shallow Invert Inches [mm]
Neutral Channel 39.37" (1m)	CHG61540-000	169.76	CHG62550-000	169.76	CHG61560-000	169.76	8.27"[210]	8.27"[210]
Neutral Channel 19.69" (0.5m)	CHG61240-000	242.51	CHG62250-000	234.79	CHG61260-000	242.51	12.20"[310]	12.20"[310]
Catch Basin 19.69" (0.5m)	CHG61540-105	98.11	CHG62550-105	98.11	CHG61560-105	99.21	12.20"[310]	12.20"[310]
Double Catch Basin 19.69" (0.5m)	CHG61240-009	317.47	CHG62250-009	317.47	CHG61260-009	317.47	43.30"[1100]	43.30"[1100]

ACCESSORIES MAXI200	Part No.
End Cap for MAXI200 (Open & Closed): 1 plastic part to close MAXI200 trench drains that can be cut to connect 8" pipes	CHG70012-00
8" Pipe Connection (PVC) for all MAXI200	CHG70022-00

Specifications

MAXI200 with Ductile Iron ADA Load Class D (Part No. CHG61240-*) and ADA Load Class F (Part No. CHG61260-*)

Channel with 2 grates, water intake area 150.35 sq. ins

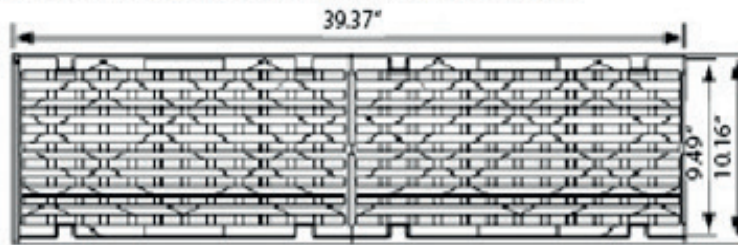

Water intake area 75.17 sq. ins

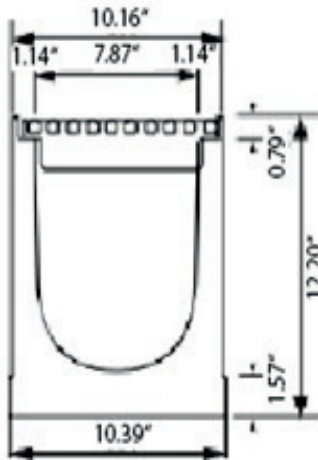
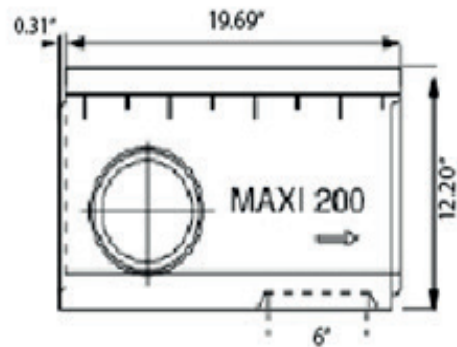
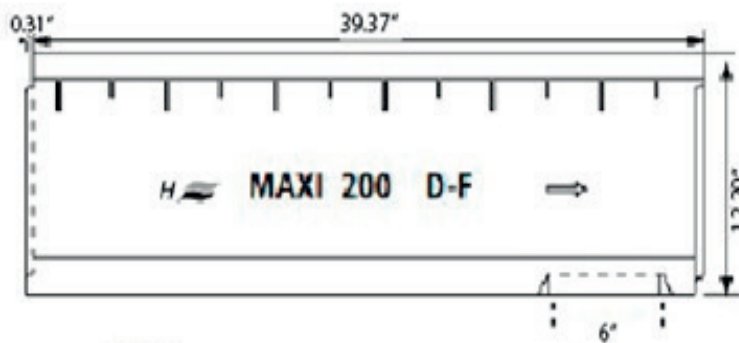
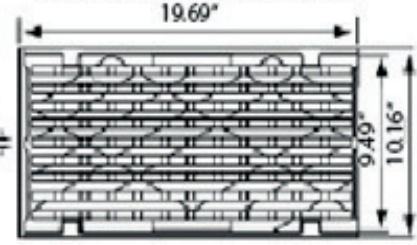

Supplied By:

Specifications

MAXI200 with Ductile Iron Class E Grate: Part No. CHG62250-*

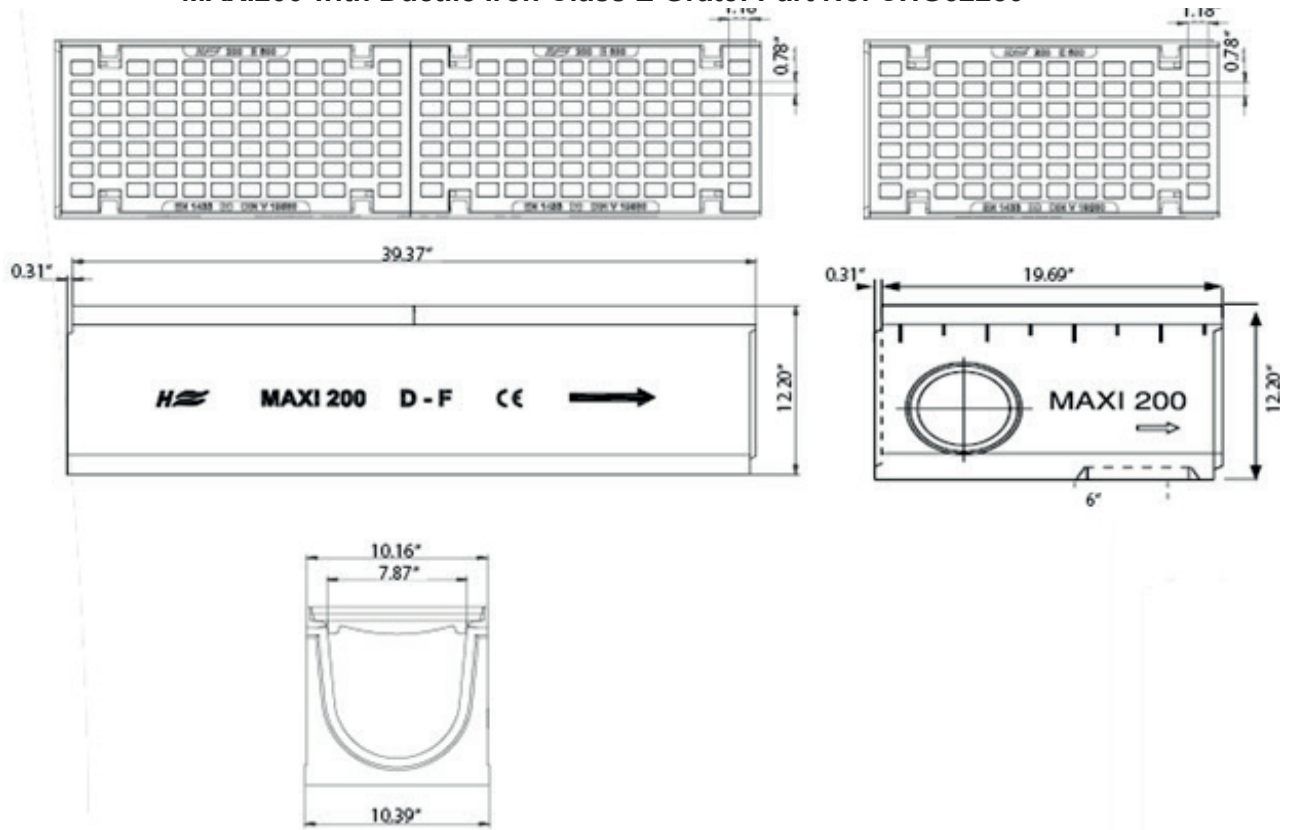

Catch Basin, Double Catch Basin and End Caps for All MAXI200



Specifications

MAXI300

12" [300] WIDE THROAT TRENCH DRAIN SYSTEM WITH DUCTILE IRON FRAME

Dimensional Data (inches and [mm]) are Subject to Manufacturing Tolerances and Change Without Notice

ENGINEERING SPECIFICATION: HYDROTEC MAXI300 Channels shall be 39.37" [1000] long, 14.96" [380] wide reveal and have a 11.81" [300] wide throat. Modular channel sections shall be made of fiber-reinforced concrete C35/45. Shall have a male/female connection between channel sections that will not separate during the installation. Channels shall have a radiused self-cleaning bottom and neutral 0% built in slope. Channels shall have Ductile Iron Edge Rails built into the fiber-reinforced concrete. Channels shall have all grates locked down as per HYDROTEC's "F1" locking mechanism.

MAXI 11.81" [300] wide throat **Ductile Iron ADA Grate is rated class E** per the DIN EN1433 top load classifications. Ductile Iron conforms to ASTM specification A536-84, Grade 80-55-06. Supplied in 39.37" [1000] or 19.69" [500] nominal lengths with 1.02/0.47 [26/12] wide slots. Grate has an open area of 52.91 sq. in per ft. [112,000 sq.mm per meter].

MAXI 11.81" [300] wide throat **Ductile Iron ADA Grate is rated class F** per the DIN EN1433 top load classifications. Ductile Iron conforms to ASTM specification A536-84, Grade 80-55-06. Supplied in 39.37" [1000] or 19.69" [500] nominal lengths with 1.02/0.47 [26/12] wide slots. Grate has an open area of 52.91 sq. in per ft. [112,000 sq.mm per meter].

MAXI300 Parts Guide

Product Description	With Ductile Iron Class E Grate Part No.	Weight Lbs	With Ductile Iron Class F Grate Part No.	Weight Lbs	'A' Shallow Invert Inches [mm]	'B' Shallow Invert Inches [mm]
Neutral Channel 39.37" (1m)	CHG66350-0501	396.83	CHG66360-0501	436.51	15.75"[400]	15.75"[400]
Neutral Channel 19.69" (0.5m)	CHG66350-0551	198.41	CHG66360-0551	202.82	15.75"[400]	15.75"[400]
Catch Basin 19.69" (0.5m)	CHG66350-0081	306.44	CHG66360-0081	306.44	29.53"[750]	29.53"[750]
Neutral Channel 39.37" (1m) with Precast Outlet Underneath	CHG66350-0571	396.83	CHG66360-0571	436.51	15.75"[400]	15.75"[400]

ACCESSORIES MAXI300	Part No.
Closed End Cap for MAXI300 made out of Cast Iron	CHG70031-11
8" Pipe Connection (PVC) for all MAXI300	CHG70022-00

Specifications

MAXI300 with Ductile Iron ADA Load Class E (Part No. CHG66350-*) and ADA Load Class F (Part No. CHG66360-*)

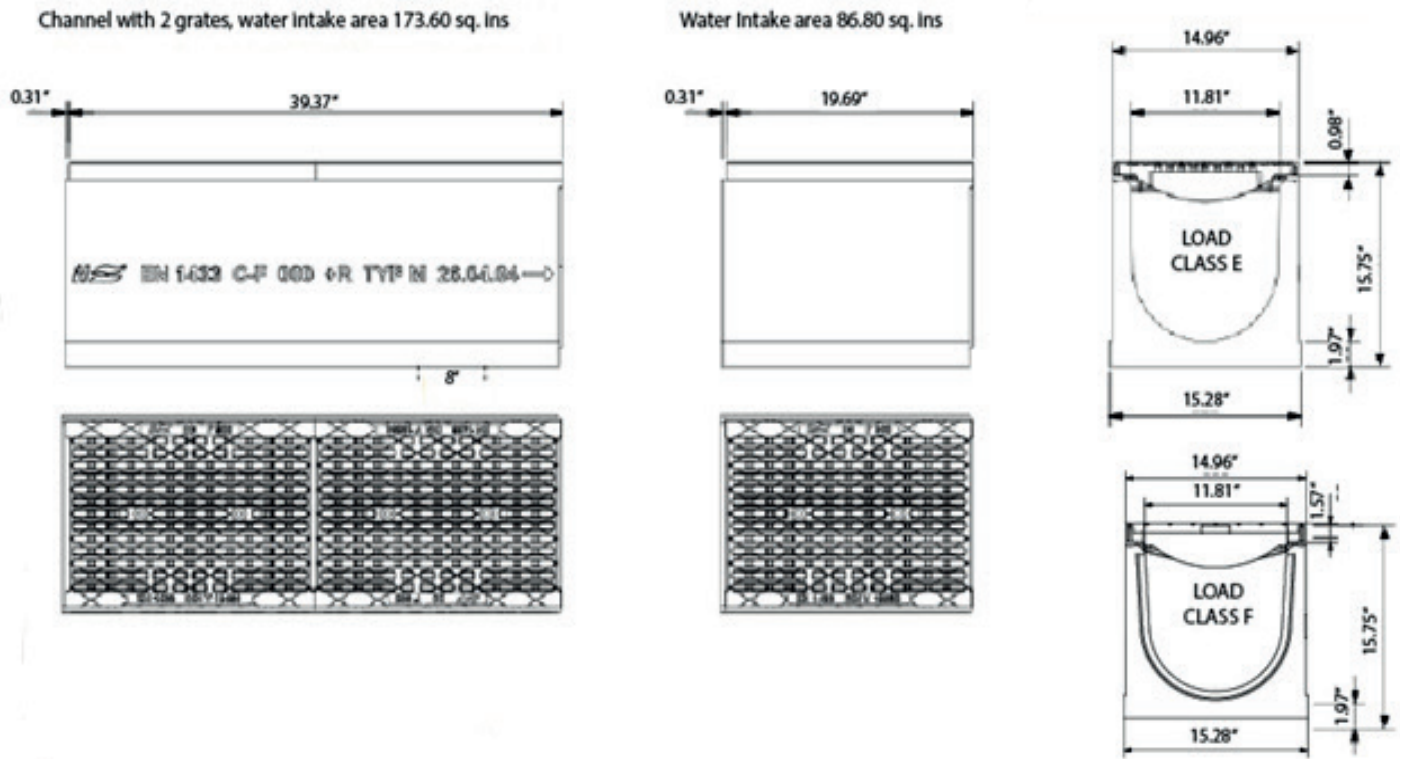

Catch Basin and End Caps for All MAXI300

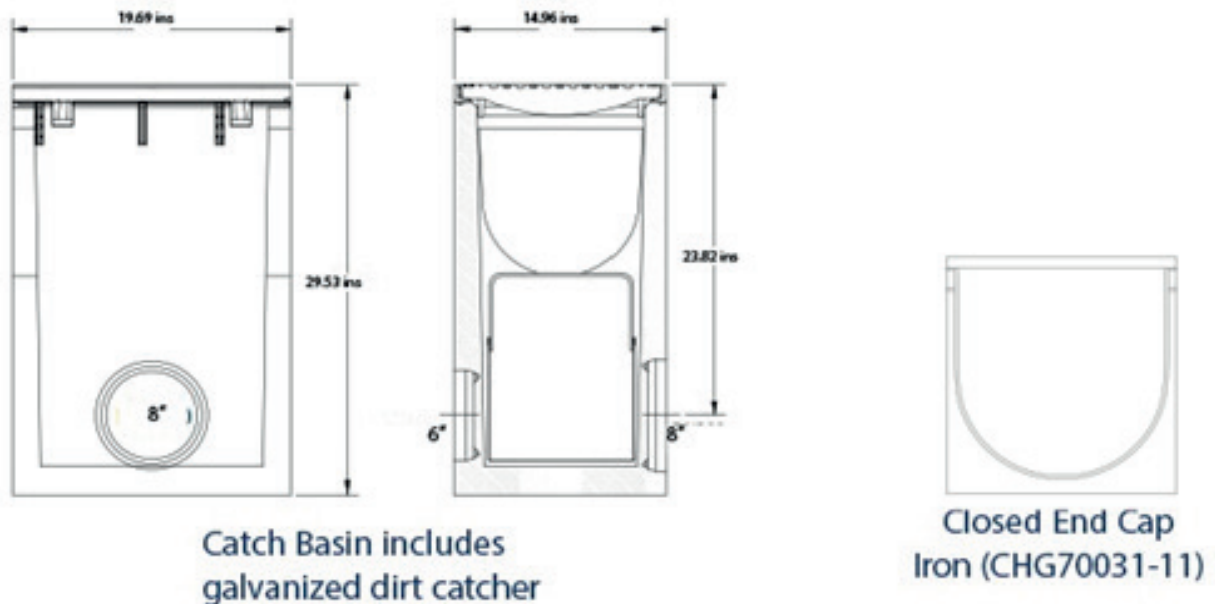

Specifications

TOP100

4" [100] WIDE THROAT TRENCH DRAIN SYSTEM WITH GALVANIZED STEEL FRAME

Dimensional Data (inches and [mm]) are Subject to Manufacturing Tolerances and Change Without Notice

ENGINEERING SPECIFICATION: HYDROTEC TOP100 Channels shall be 39.37" [1000] long, 6.22" [158] wide reveal and have a 3.94" [100] wide throat. Modular channel sections shall be made of fiber-reinforced concrete C35/45. Shall have a male/female connection between channel sections that will not separate during the installation. Channels shall have a radiused self-cleaning bottom and 0.5% or neutral 0% built in slope. Channels shall have Galvanized Steel Edge Rails built into the fiber-reinforced concrete. Channels shall have all grates locked down as per HYDROTEC's patented locking mechanism whereby the polyamide rod is pushed and locked underneath the grate.

TOP 3.94" [100] wide throat **Galvanized Steel Slot ADA Grate is rated class A** per the DIN EN1433 top load classifications. Supplied in 39.37" [1000] or 19.69" [500] nominal lengths with 3.94/0.39 [100/10] wide slots. Grate has an open area of 16.96 sq. in per ft. [35,900 sq.mm per meter].

TOP 3.94" [100] wide throat **Galvanized Steel Slot ADA Grate is rated class C** per the DIN EN1433 top load classifications. Supplied in 39.37" [1000] or 19.69" [500] nominal lengths with 3.94/0.39 [100/10] wide slots. Grate has an open area of 16.96 sq. in per ft. [35,900 sq.mm per meter].

TOP 3.94" [100] wide throat **Galvanized Steel Mesh Grate is rated class C** per the DIN EN1433 top load classifications. Supplied in 39.37" [1000] or 19.69" [500] nominal lengths with 1.21/0.57 [30.8/14.5] wide slots. Grate has an open area of 47.71 sq. in per ft. [101,000 sq.mm per meter].

TOP 3.94" [100] throat **Ductile Iron Grate is rated class C** per the DIN EN1433 top load classifications. Ductile Iron conforms to ASTM specification A536-84, Grade 80-55-06. Supplied in 39.37" [1000] or 19.69" [500] nominal lengths with 4.72/0.55 [120/14] wide slots. Grate has an open area of 26.64 sq. in per ft. [56,395 sq.mm per meter].

Guide to Pre-Sloped Modular System

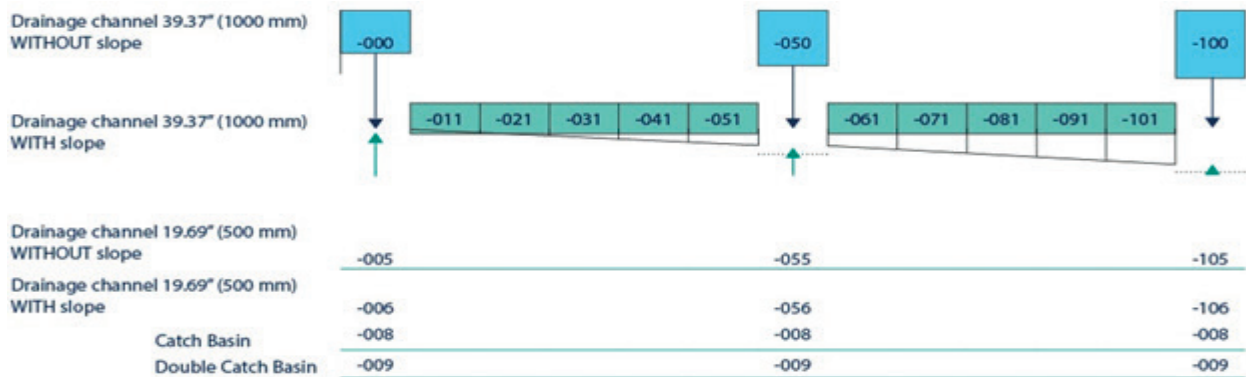

Specifications

TOP100 Parts Guide

Product Description	With Galvanized Steel Slot ADA Class A Grate Part No.	Weight Lbs	With Galvanized Steel Slot ADA Class C Grate Part No.	Weight Lbs	With Galvanized Steel Mesh ADA Class C Grate Part No.	Weight Lbs	With Ductile Iron ADA Class C Grate Part No.	Weight Lbs	'A' Shallow Invert Inches [mm]	'B' Shallow Invert Inches [mm]
Neutral Channel 39.37" (1m)	CHG63210-000	70.5	CHG63430-000	76.1	CHG63230-000	75.0	CHG63130-000	102.74	6.30"[160]	6.30"[160]
Neutral Channel 19.69" (0.5m)	CHG63210-005	35.3	CHG63430-005	38.6	CHG63230-005	37.5	CHG63130-005	50.71	6.30"[160]	6.30"[160]
T1 Sloped Channel 39.37" (1m)	CHG63210-011	73.8	CHG63430-011	80.5	CHG63230-011	78.3	CHG63130-011	103.62	6.30"[160]	6.50"[165]
T2 Sloped Channel 39.37" (1m)	CHG63210-021	76.1	CHG63430-021	81.6	CHG63230-021	80.5	CHG63130-021	104.72	6.50"[165]	6.69"[170]
T3 Sloped Channel 39.37" (1m)	CHG63210-031	78.3	CHG63430-031	83.8	CHG63230-031	82.7	CHG63130-031	105.82	6.69"[170]	6.89"[175]
T4 Sloped Channel 39.37" (1m)	CHG63210-041	79.4	CHG63430-041	84.9	CHG63230-041	83.8	CHG63130-041	106.92	6.89"[175]	7.09"[180]
T5 Sloped Channel 39.37" (1m)	CHG63210-051	81.6	CHG63430-051	87.1	CHG63230-051	85.6	CHG63130-051	108.03	7.09"[180]	7.28"[185]
Neutral Channel 39.37" (1m)	CHG63210-050	82.7	CHG63430-050	88.2	CHG63230-050	87.1	CHG63130-050	108.47	7.28"[185]	7.28"[185]
Neutral Channel 19.69" (0.5m)	CHG63210-055	41.9	CHG63430-055	45.2	CHG63230-055	44.1	CHG63130-055	57.32	7.28"[185]	7.28"[185]
T6 Sloped Channel 39.37" (1m)	CHG63210-061	83.8	CHG63430-061	89.3	CHG63230-061	88.2	CHG63130-061	109.57	7.28"[185]	7.48"[190]
T7 Sloped Channel 39.37" (1m)	CHG63210-071	87.1	CHG63430-071	92.6	CHG63230-071	91.5	CHG63130-071	111.33	7.48"[190]	7.68"[195]
T8 Sloped Channel 39.37" (1m)	CHG63210-081	88.2	CHG63430-081	93.7	CHG63230-081	92.6	CHG63130-081	112.88	7.68"[195]	7.87"[200]
T9 Sloped Channel 39.37" (1m)	CHG63210-091	92.6	CHG63430-091	98.2	CHG63230-091	97.0	CHG63130-091	114.42	7.87"[200]	8.07"[205]
T10 Sloped Channel 39.37" (1m)	CHG63210-101	94.8	CHG63430-101	100.3	CHG63230-101	99.3	CHG63130-101	115.96	8.07"[205]	8.27"[210]
Neutral Channel 39.37" (1m)	CHG63210-100	95.9	CHG63430-100	102.6	CHG63230-100	100.3	CHG63130-100	116.62	8.27"[210]	8.27"[210]
Neutral Channel 19.69" (0.5m)	CHG63210-105	46.3	CHG63430-105	49.6	CHG63230-105	48.5	CHG63130-105	59.52	8.27"[210]	8.27"[210]
Catch Basin 19.69" (0.5m)	CHG63210-008	100.3	CHG63430-008	103.6	CHG63230-008	103.6	CHG63130-008	109.1	19.69"[500]	19.69"[500]

ACCESSORIES TOP100	Part No.
Closed End Cap for All TOP100 (2 Parts: Plastic Support + Galvanized Steel Cap)	CHG70011-10
Closed End Cap for 6.30" TOP100 (1 Iron Part)	CHG70011-11
Closed End Cap for 7.28" TOP100 (1 Iron Part)	CHG70011-12
Open End Cap for All TOP100 with Connection to 4" Pipe (2 Parts: Plastic Support + Galvanized Steel Cap)	CHG70011-20
4" Pipe Connection (PVC) for all TOP100	CHG70021-00
6" Pipe Connection (PVC) for all TOP100	CHG70021-60

Specifications

**TOP100 with Galvanized Steel Slot ADA Load Class A (Part No. CHG63210-*)
or C Grate: Part No. CHG63430-*)**

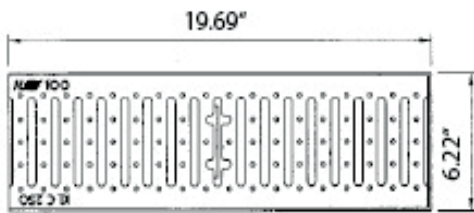
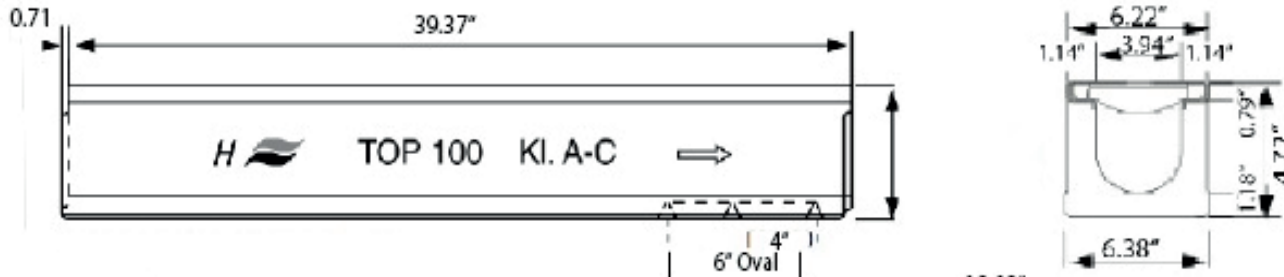

Water Intake area 27.82 sq. ins.

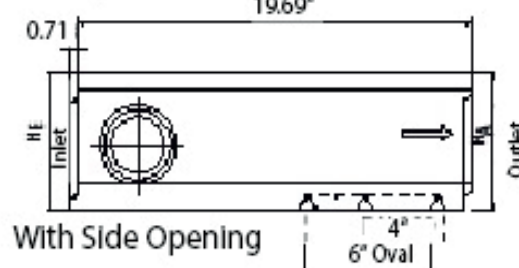

With Side Opening

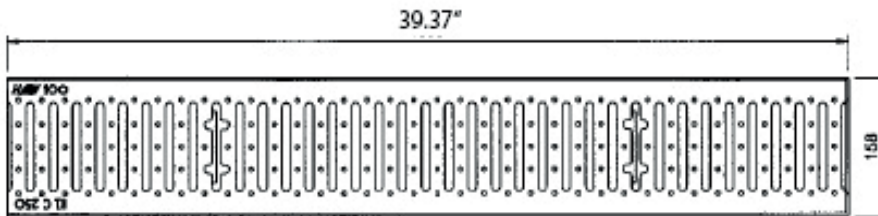

Water Intake area 55.65 sq. ins.

TOP100 with Galvanized Steel Mesh Load Class C Grate: Part No. CHG63230-*)

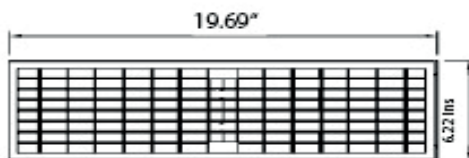
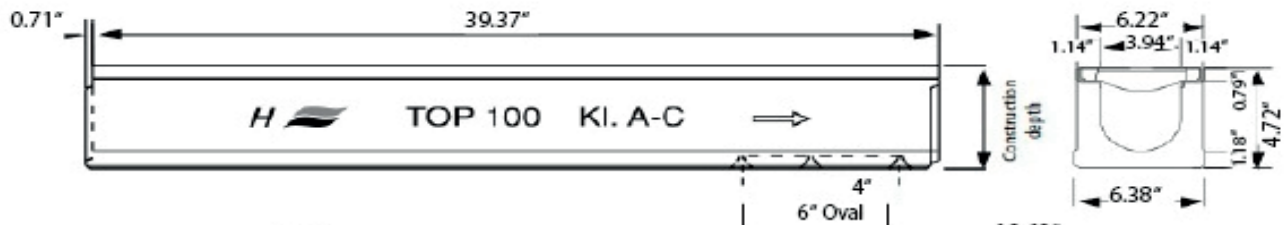

Water Intake area 78.27 sq. ins.



With Side Opening



mesh 1.18"/0.59"

Water Intake area 156.55 sq. ins.

Specifications

TOP100 with Ductile Iron Class C Grate: Part No. CHG63130-*

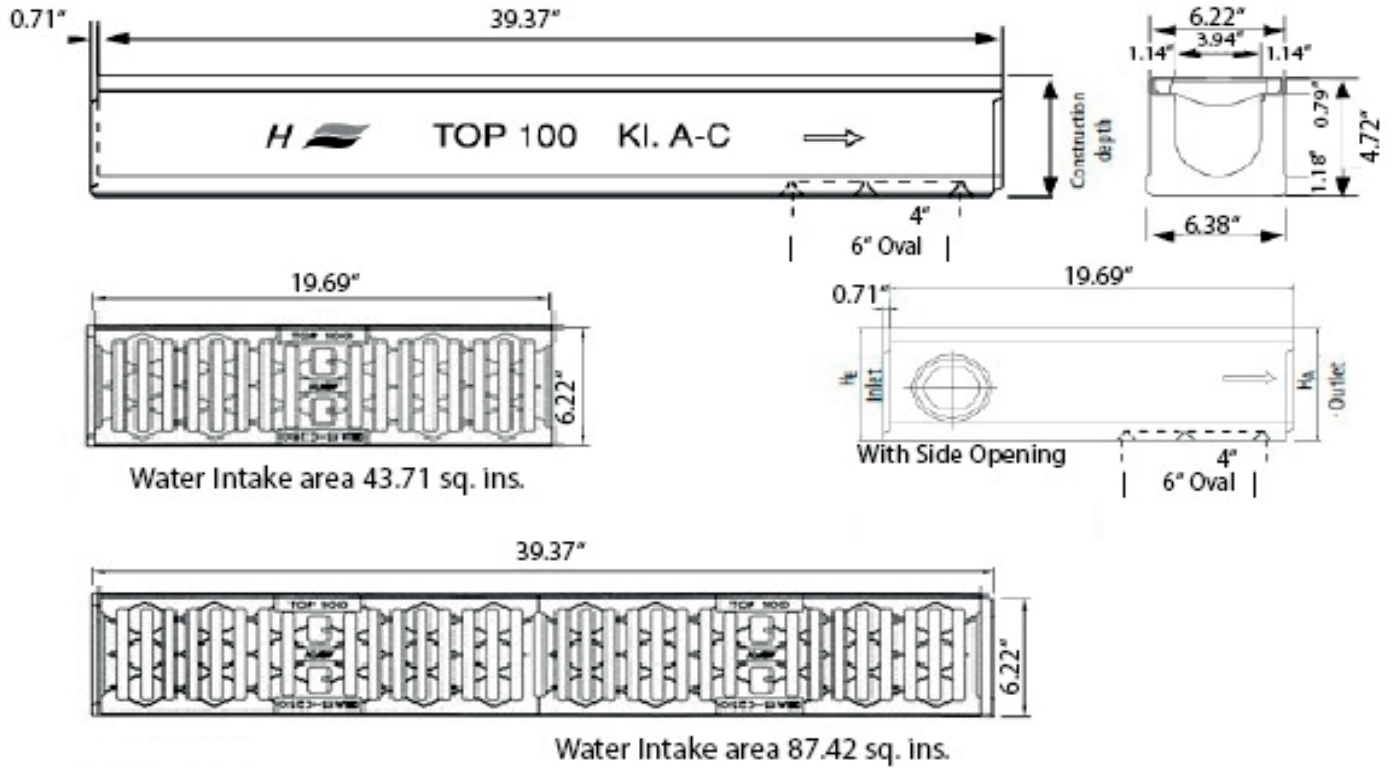

Catch Basin and End Caps for All TOP100

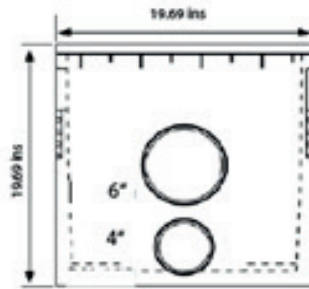

Catch Basin
incl. galvanized dirt
catcher



Closed End Piece
Part.No.:
CHG70011-10



Open End Piece with 4"
Pipe Connection
Part.No.: CHG70011-20



Quality – Service – Commitment – Delivered.

www.sigmaco.com

TECHNICAL RESOURCES



HYDROTEC ®
Technologies

Rev 4/30/15

Hydraulic Calculation

Catchment depth

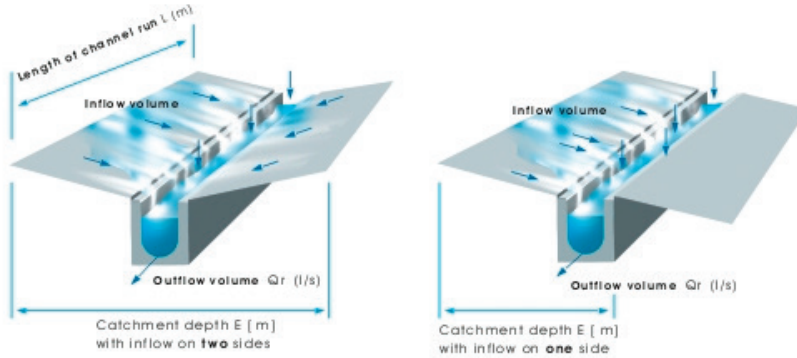

Outflow volume / Water level / Base formation

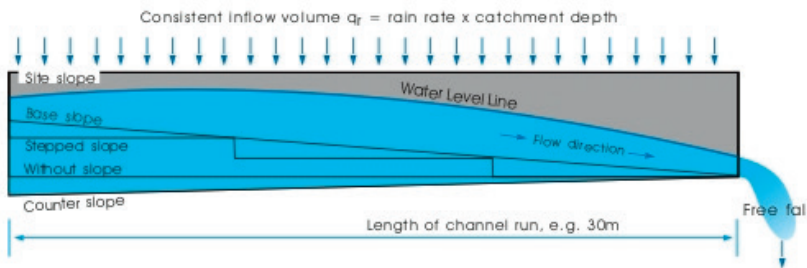

The shape of the channel base with or without slope has no effect on the outflow volume of the channel run. The water level remains constant. The outflow volume is determined only by the inner channel diameter at the end of the run, the slope has no impact at all. **Result: less effort without slope.**

Calculating the maximum channel run

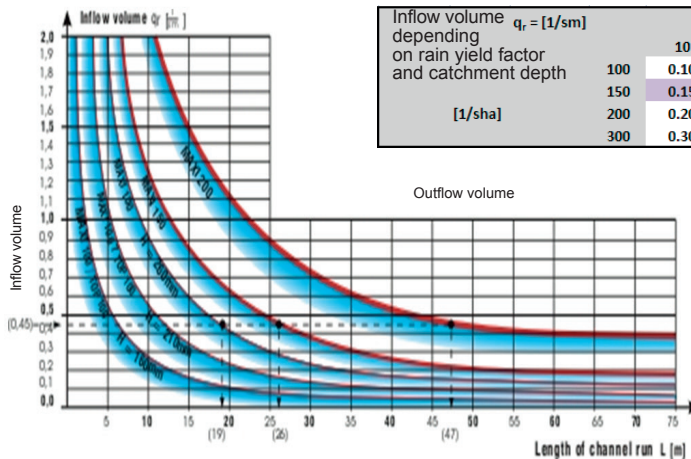

Inflow volume $q_r = [1/\text{sha}]$ depending on rain yield factor and catchment depth	Catchment depth E[m]					
	10	15	20	30	40	50
100	0.10	0.15	0.20	0.30	0.40	0.50
150	0.15	0.23	0.30	0.45	0.60	0.75
200	0.20	0.30	0.40	0.60	0.80	1.00
300	0.30	0.45	0.60	0.90	1.20	1.50

Example:

The aim is to determine the maximum length L of a channel run.

The catchment depth E is 30m. The rain yield factor is given as 150.

Solution in line with Table 1:

The inflow volume is $q_r = 0.45$

A length of $L = 19\text{m}$ can be read off in the diagram for the MAXI 100.

If the length of the MAXI 100 channel exceeds 19m, it will be unable to drain off the intake of water. In this case you should select a greater effective height or nominal width. The length is $L = 26\text{m}$ for MAXI 150 and $L = 47\text{m}$ for MAXI 200.

Outflow volume "Q" of ground pipe

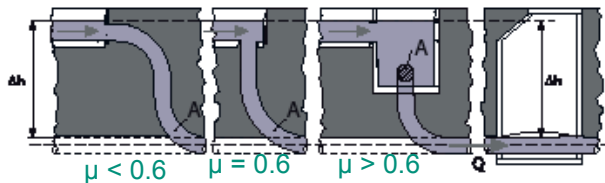

Sewer DN	A [d m ²]	Outflow volume Q [l/s]			
		0.35	1	2	Δh [m]
110	0.85	0.6	0.6	0.6	μ
160	1.82	13.4	22.6	32	
200	2.87	28.6	48.4	68.5	
		45.1	76.3	108	

$$Q = \mu \cdot A \cdot \sqrt{(2g \cdot \Delta h)}$$

Outflow Rates

Outflow rates

DRAIN TYPE	Nominal size b (mm)	Height H (mm)	Clear Height h (mm)	Cross-Section A (cm ²)	Reduction Factor μ	max. Drain Capacity Liter/s $Q=\mu A \cdot \sqrt{2 \cdot g \cdot \Delta h}$	max. Drain Capacity Gallons per minute (GPM)
MINI A	100	120	80	69	0,8	2,19	34,62
MINI B	100	120	60	49	0,8	1,34	21,29
TOP / MAXI	100	160	90	79	0,8	2,66	42,04
	100	185	115	104	0,8	3,95	62,57
	100	210	140	129	0,8	5,41	85,63
	100	235	165	154	0,8	7,01	110,97
	100	260	190	179	0,8	8,74	138,41
MAXI	150	210	115	148	0,8	5,62	89,04
	150	235	140	186	0,8	7,80	123,46
	150	260	165	223	0,8	10,15	160,69
	150	310	215	298	0,8	15,48	245,12
MAXI	200	310	205	367	0,8	18,62	294,78
MAXI F1	300	400	300	802	0,8	49,22	779,27
HYDROblock	100	180	100	78	0,9	3,11	49,23
HYDROblock	200	295	200	313	0,9	17,65	279,36
HYDROblock	300	413	300	700	0,9	48,33	765,18

Horizontal Outflow

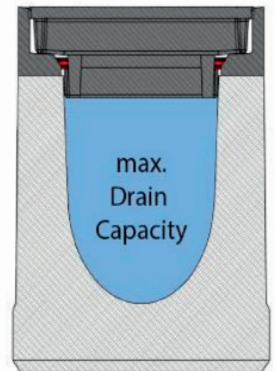

Drain type	Outlet Size	Invert Depth	Liters/sec	Gallons per Minute (GPM)	Cubic feet per sec (CFS)
MINI 100	100 mm	85	6,59	104	0,23
Top/MAXI 100	100 mm	120	7,83	124	0,28
Top/MAXI 100	100 mm	220	10,60	168	0,37
Top/MAXI 100	150 mm OVAL	120	11,78	187	0,42
Top/MAXI 100	150 mm OVAL	220	15,96	253	0,56
MAXI 150	150 mm	170	19,94	316	0,70
MAXI 150	150 mm	270	25,13	398	0,89
MAXI 200	150 mm	270	25,13	398	0,89
MAXI 300	200 mm	350	45,12	714	1,59
MAXI 300	250 mm	350	74,06	1172	2,61
HYDROblock 100	100 mm	100	7,14	113	0,25
HYDROblock 200	150 mm	200	21,63	342	0,76
HYDROblock 300	250 mm	300	68,56	1085	2,42

Vertical Outflow

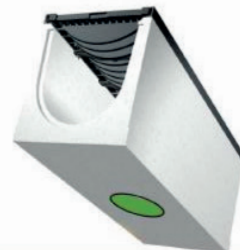

Supplied By:

**TRENCHDRAIN
SUPPLY**

877-903-7246

www.trenchdrainsupply.com

Chemical Resistance



Medium	Temperatures up to (°F)	HYDROTEC Fiber reinforced Concrete (C35/45)*
Acetic acid 10%	75	-
Acetone	75	-
Ammonia 25% aqueous solution	75	+
Ammonia 5% aqueous solution	75	+
Ammonium salts, aqueous solution	75	-
Apple juice, aqueous solution	75	+
Barium salts, aqueous solution	75	+
Battery acid (dil. sulphuric acid)	75	-
Beer	75	-
Benzene	75	-
Blood	75	-
Butanol	75	-
Carbon tetrachloride	75	+
Carbonic acid, aqueous solution	75	-
Castor oil	75	+
Chlorinated lime, aqueous solution	75	-
Chlorine water	75	+
Chlorine, gaseous, wet	75	+
Chromic acid 10%	75	-
Citric acid, aqueous solution	75	-
Citric acid, aqueous solution	140	-
Copper salts, aqueous solution	75	-
Crude oil	75	-
Cyclohexane	75	-
Detergent, commercial 5%	75	+
Developer	75	-
Diesel oil	75	-
Distilled water	75	+
Distilled water	140	+
Epoxy resins	75	-
Ethanol	75	+
Ethylbenzol	75	-
Fatty acids (higher than and incl. C 12)	104	-
Fish oil	75	-
Fixer	75	-
Formaldehyde, aqueous solution	75	+
Formic acid 10%	75	-
Fruit juices	75	+
Fuel oil	75	-
Glycerin	75	-
Glycol (ethylene glycol)	75	-
Greases	75	+
Humic acid	75	-
Hydrofluorosilicic acid	68	-
Hydrogen bromide	75	-
Iron salts, aqueous solution	75	+
Isopropyl alcohol (2-propanol)	75	-
Jet fuel	75	-

Medium	Temperatures up to (°F)	HYDROTEC Fiber reinforced Concrete (C35/45)*
Lactic acid, aqueous solution	75	-
Linseed oil	75	-
Machine oil	75	+
Magnesium salts, aqueous solution	75	+
Maleinic acid, aqueous solution	75	-
Malic acid	86	-
Manganese salts, aqueous solution	75	-
Margarine	75	+
Milk	75	-
Mineral oils	75	-
Mineral water	75	-
Nitric acid 10%	104	-
Octane	75	-
Octane	140	-
Oleic acid	75	+
Oxalic acid, aqueous solution	75	+
Oxalic acid, aqueous solution	140	+
Paraffin oil	75	+
Perchloric acid	75	-
Petrol, super and normal	75	-
Petroleum	75	+
Petroleum ether	75	+
Phosphoric acid 10%	75	-
Phosphoric acid 10%	140	-
Phosphoric acid 50%	104	-
Potash lye 2.5%	75	+
Potassium permanganate 6%	140	+
Potassium salts, aqueous solution	75	+
Raw oil	75	+
Salicylic acid, aqueous solution	75	-
Seawater	75	-
Seawater	140	-
Silicone oil	75	+
Sodium hydroxide 40%	104	+
Sodium salts, aqueous solution	75	+
Soil, acidic and alkaline	75	+
Succinic acid, aqueous solution	75	-
Sugar	75	+
Sulphuric acid 30%	75	-
Tetrachloroethylene	75	+
Thioglycolic acid	75	-
Tin salts, aqueous solution	75	-
Trichloroethylene	75	+
Urea, aqueous solution	75	-
Wetting and cleaning agents	75	-
Wine	75	+
Zinc salts, aqueous solution	75	-
Jet fuel	75	-

+ = resistant
- = not resistant

*Specifications without engagement, subject to errors and modifications. If medium is not listed, please contact your HYDROTEC partner.



Precast Concrete Trench Drain Solutions

ENVIRONMENTAL IMPACT



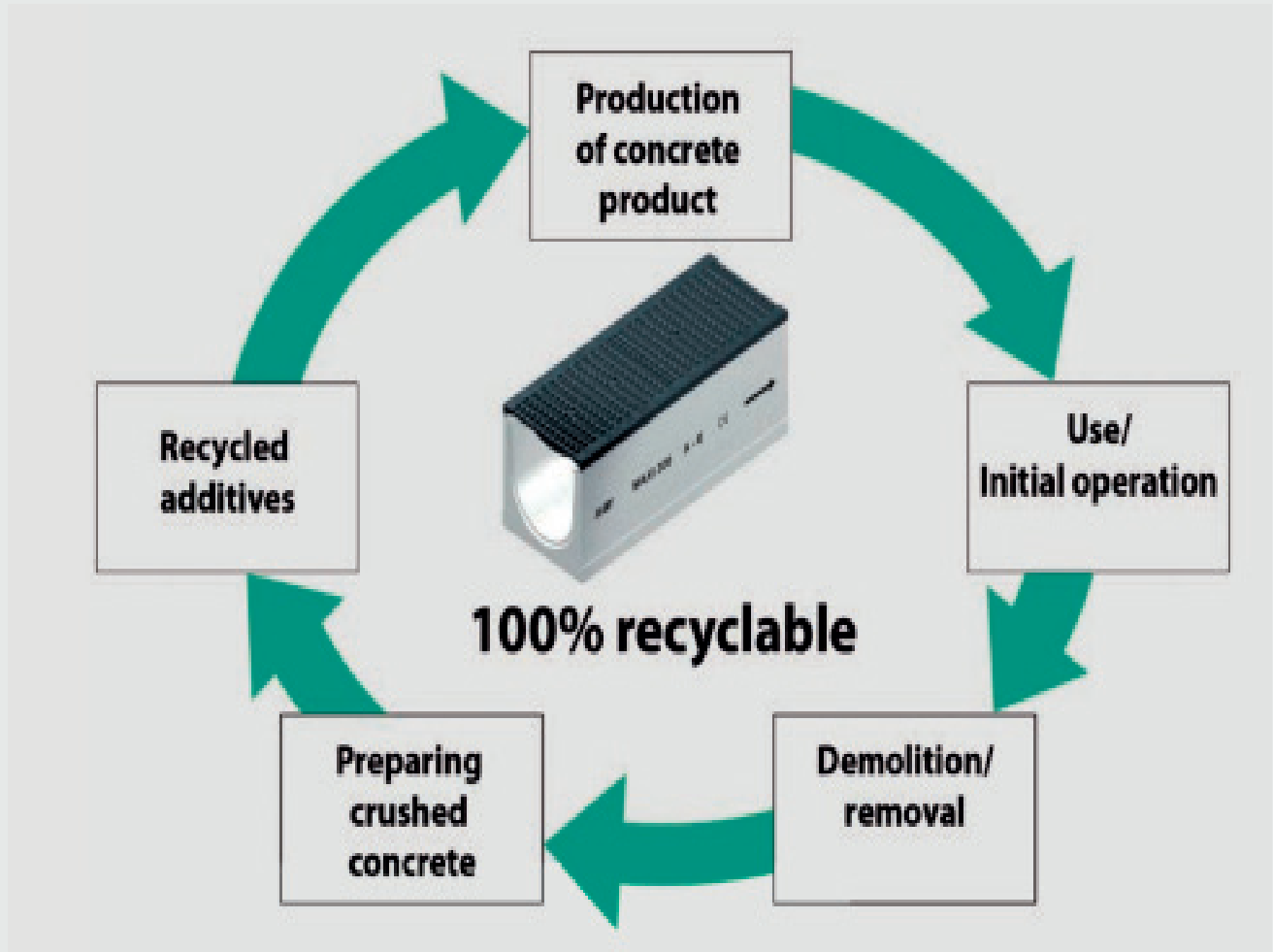

**Positive eco-balance -
Drainage system of fiber-reinforced concrete**



Sustainability in the spotlight

HYDROTEC always selects the raw materials for its fibre-reinforced concrete with ecological perspectives in mind. The basis for concrete is simple, and nature offers what we need to make it: cement from limestone and clay, aggregate from sand and/or gravel and, finally, water. These raw materials are abundantly present as natural reserves in the long term and give the concrete a very long lifespan and the associated properties. Safety, resilience, ability to be moulded and economic viability made concrete one of the most important construction materials - then, now and in the future.

Made in Germany

HYDROTEC has been producing its fibre-reinforced concrete drainage channels in Germany for 45 years. At the Wildeshausen factory, over 90 highly-qualified employees guarantee quality, efficiency and environmental sustainability in every working process.

Positive ecological balance as a sign of quality

Concrete is one of the few materials which have an extremely strong eco-balance. The highest possible ecological requirements are already fulfilled when raw materials which were extracted in an environmentally friendly way are selected. In contrast with other materials, the production of concrete requires a very low amount of energy. At the end of its lifespan, concrete can be completely recycled, which keeps its environmental footprint to a minimum.

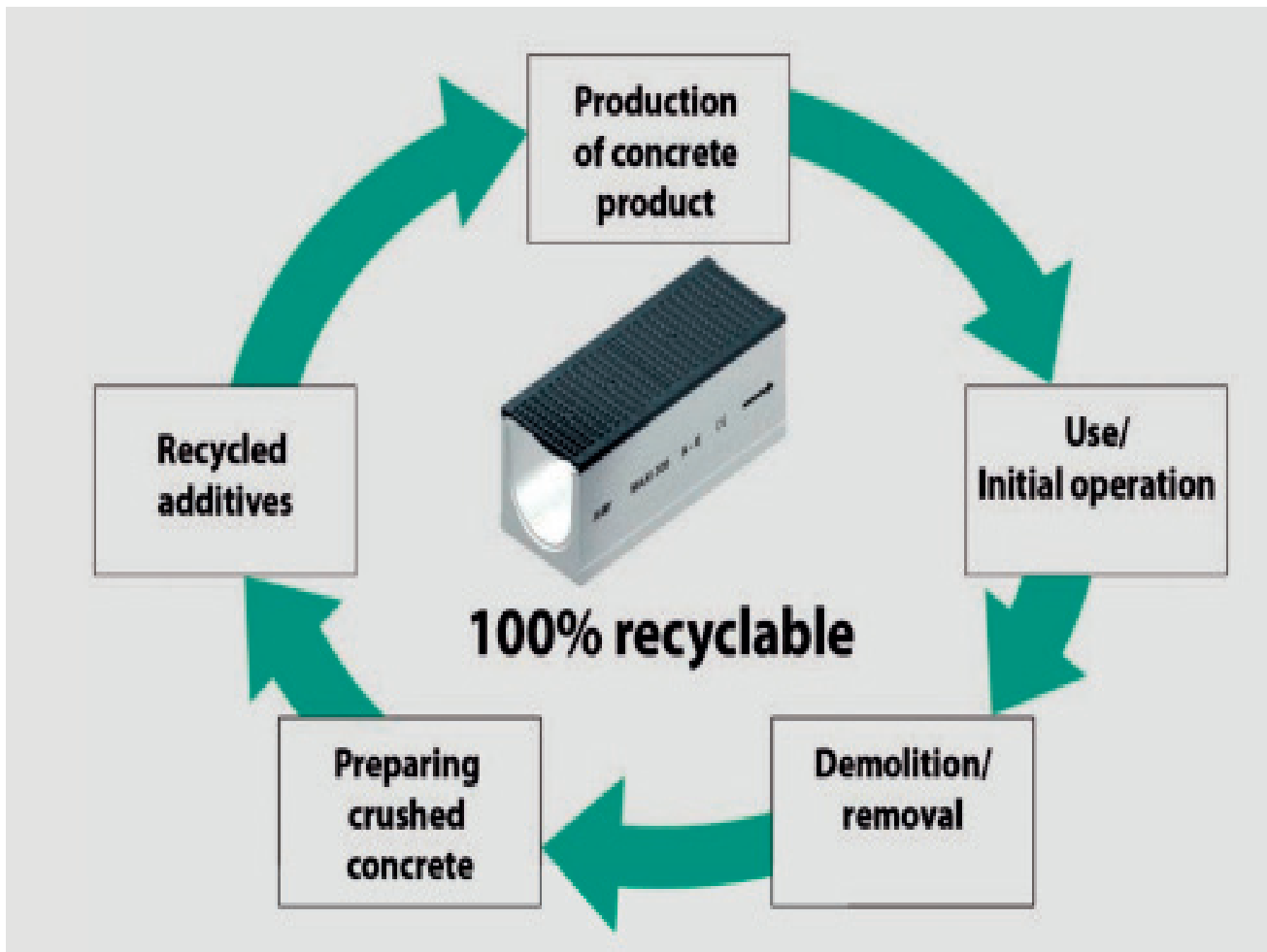

Positive eco-balance as a sign of quality

Concrete is by far the material which is produced in the most energy efficient way, as clearly shown in the below diagram. The regional availability in all parts of Germany is only one indicator which shows that the raw materials required for producing concrete may be transported and processed with little effort. Only the production of cement requires a similar level of energy use, which, given the low proportion of approx. 15% in concrete, does not have a significant influence.

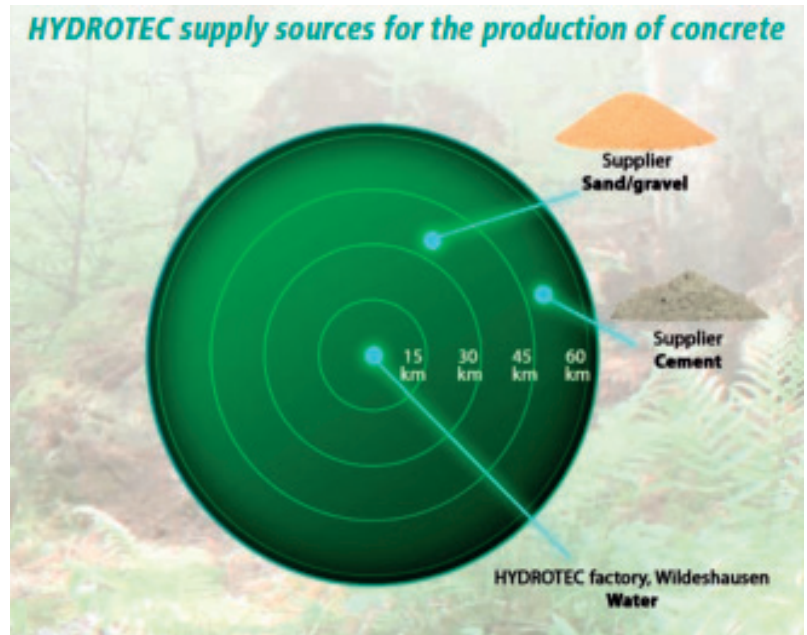

Primary energy requirements for the production of ...

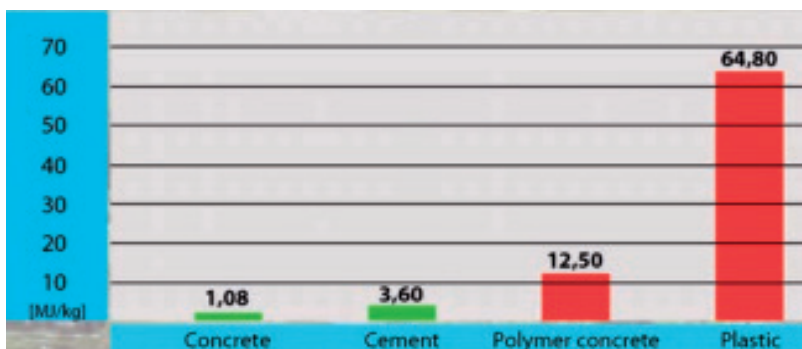

Ecology combined with economy is our goal in concrete production. This goal is achieved particularly through short transport routes, which not only protect the environment, but also keep transit costs low. In order to achieve this goal, HYDROTEC deliberately selects suppliers from the region.

Positive eco-balance as a sign of quality

CO2 emissions for the production of...

In comparison with other materials, such as polymer concrete or plastic, concrete produces a significantly lower amount of CO2 emissions in the production process. This leads to a reduction in CO2 of approx. 60% by comparison with polymer concrete and nearly 80% in comparison with the production of plastic.

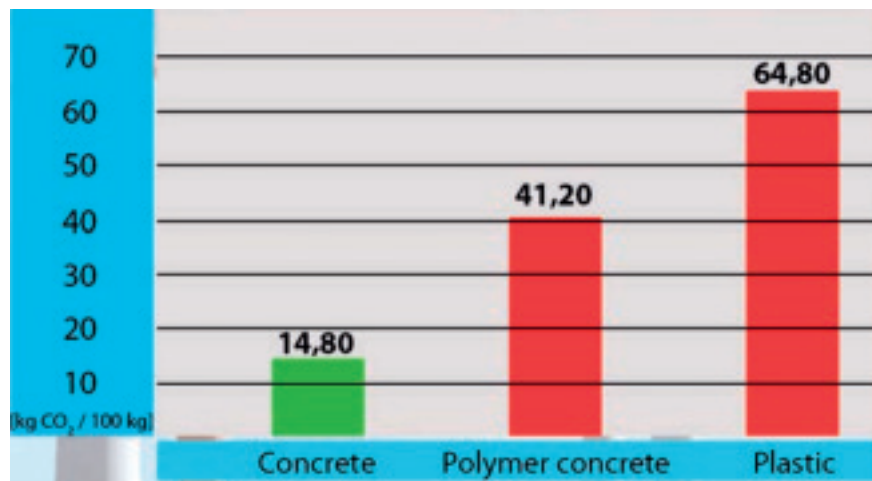

Cement on an environmental upswing

In recent years, there has been a noticeable development in the use of cement with regard to the switch from primary to secondary energy. This clear trend pursues a clear goal: minimising primary energy and maximising secondary energy.

Specific energy use in cement production

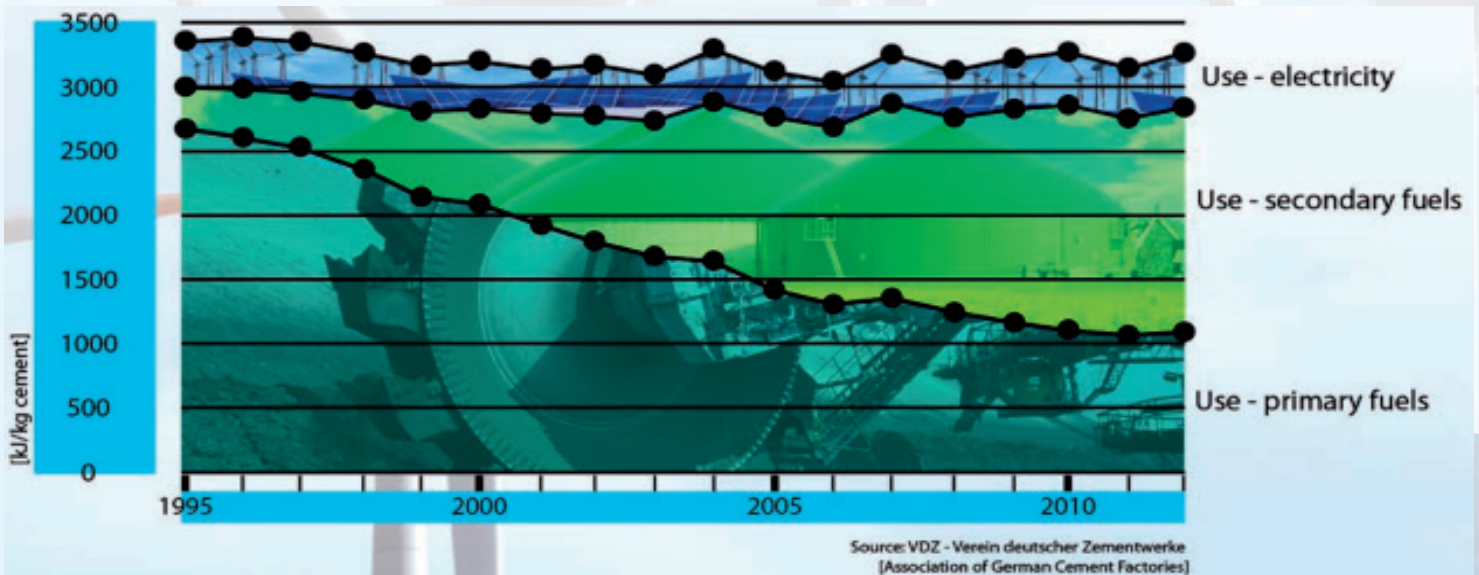

Cement on an environmental upswing

As cement production is energy and raw material-intensive, the cement industry is continuously developing new ways to reduce the use of primary raw materials, such as using alternative fuels. The German cement industry recognised these possibilities early on and is now a global leader, particularly in the use of suitable alternative fuels. In 2011, over 60% of the fuel energy required was substituted with replacement fuels in Germany.

Development of alternative fuel use in the German cement industry

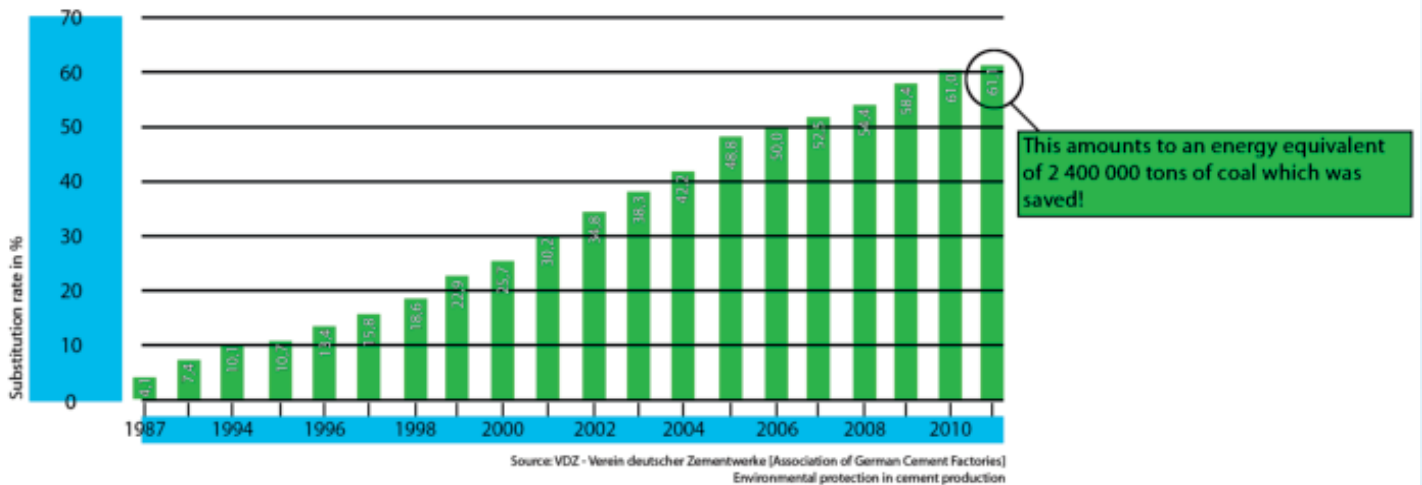

Cement on an environmental upswing

Quelle: Energie MW
Deutschlands Energieverbrauch



provide **3 000 000 households** with electricity for a whole year. This applies to three-person households with an average energy use of 6500 kWh.

Quelle: Germanischer Lloyd
Containerchiffre – Wachstum oder Ende?



make **200 round-the-world trips** with a huge container ship with a load of 9000 containers and fuel usage of 200 tons/day

The saving of **2,400,000 tons of coal** is enough to:

Quelle: www.mercedes
Zur Oktoberfest in Zehn



celebrate **3500 Oktoberfests** and cover their entire energy requirements. The electricity and gas requirements per Oktoberfest are around 5.5 million kWh.

Quelle: www.enrgy.com.au/australia/
Deutscher Energieverbrauch



heat **1 650 000 apartments** for a whole year. The apartments are 75m² with an oil heating requirement of 1155 litres/year.

Resistant and watertight

HYDROTEC drainage systems have Class C35/45 pressure resistance in accordance with DIN EN 206. However, the concrete is analysed not only according to its load-dependent effects but its effects which are not dependent on load. The various exposure classes give an indication of what kind of environmental effect the concrete involved must deal with in the long term.

Exposure class	Description of area of use	Example for classification of exposure classes	Minimum pressure resistance class
XC4	switches between wet and dry	exterior building components directly affected by rain	C 25/30
XD3	switches between wet and dry	parts of bridges often under strain from chloride-containing spray water	C 35/45
XS3	tidal areas, spray water and spray areas	quay walls in port facilities	C 35/45
XF3	high water saturation, no deicing agent	open water containers	C 35/45
XA3	chemically strong, invasive area	industrial waste water facilities with chemically invasive waste water	C 35/45

Full description in DIN 1045-2

**tested
Quality**

Resistant and watertight

The high quality of the concrete in HYDROTEC drainage channels C35/45 allows a waterproof drainage system to be created. The maximum water penetration depth of 8mm, along with the professional pointing of individual channel elements, guarantee a secure and complete drainage of liquids. The well-conceived MAXI drainage channels have a tongue and groove joint which allows the individual parts to be quickly and tightly joined together.

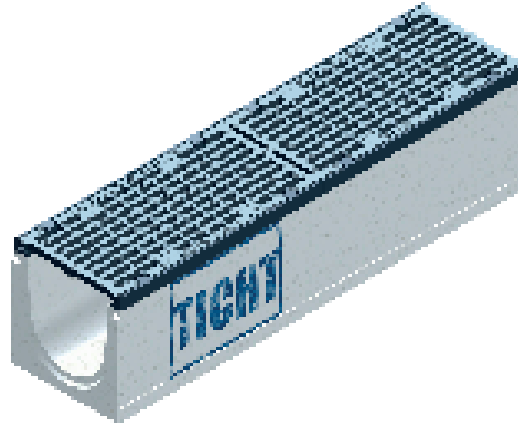

Supplied By:

TRENCHDRAIN
SUPPLY

877-903-7246

www.trenchdrainsupply.com

Highest stability, best join

HYDROTEC drainage channels, with their own high weight, guarantee a high level of stability in position which leads to quick and smooth installation.

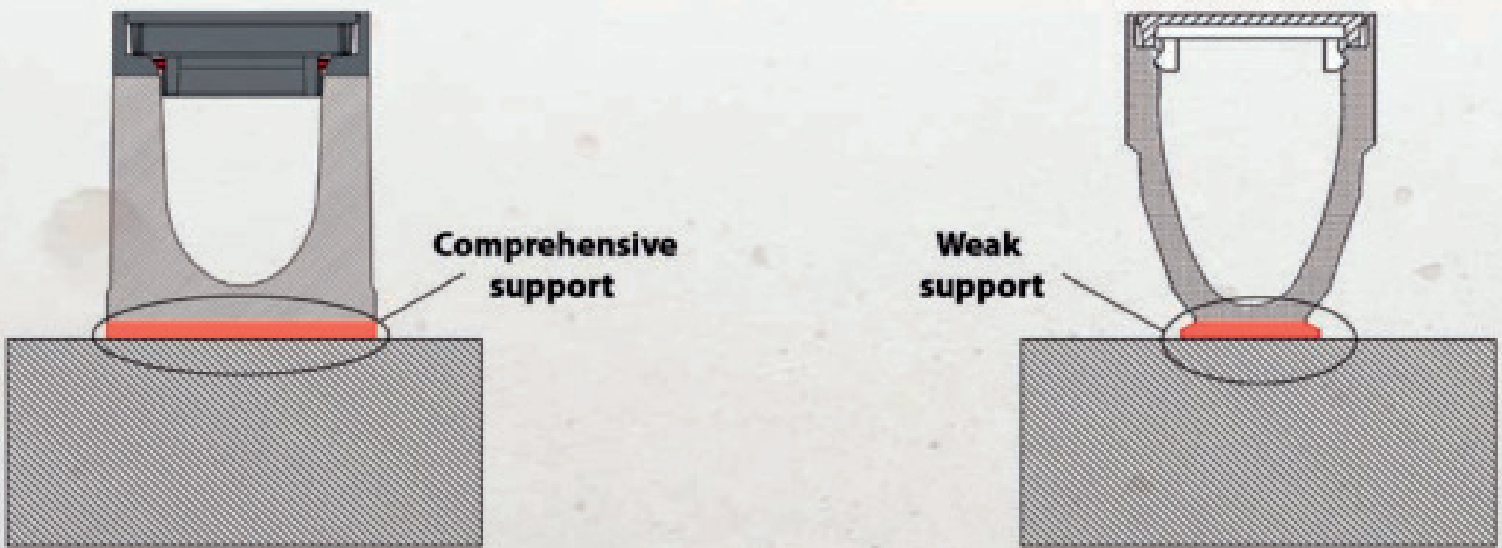

MAXI drainage channel made of fibre-reinforced concrete

Polymer concrete drainage channel

The MAXI drainage channel offers comprehensive support which guarantees stable and fixed positioning during installation. Compared to drainage channels made of polymer concrete, the MAXI drainage channel has a much larger support surface, omitting the risk of wobbling/toppling.

Highest stability, perfect join



Perfect join between concrete and concrete

Weak join between different materials

A perfect unit is built from a MAXI drainage channel and the base and/or concrete cladding due to almost identical material properties. This combination has a strong join, as two identical materials join to form one unit. The properties of polymer concrete differ from natural concrete due to the use of polyester resin as a binding agent.

Fireproofing included

HYDROTEC drainage channels are not only resistant to high temperatures, but are not flammable according to DIN 4102! If there is an accident with flammable liquids in the concrete drainage channel, then:



The drainage channels made from concrete cannot be set alight!



No poisonous gases occur!



The drainage channel is not damaged!



Fireproofing included

In case of fire, where temperatures may reach up to 1000°C, the high performance of concrete prevents the fire from spreading through the concrete, as concrete is not flammable. These specific qualities of concrete allow planners in particular to create a fireproof building for clients.





Quality – Service – Commitment – Delivered.

www.sigmaco.com

ADDITIONAL INFORMATION



HYDROTEC 

Technologies

Rev 4/30/15

Accessories for all Trench Drain Systems

ARTICLE	SAMPLE	PART NO.
Grate Locking Tool		CHG70099-00
Cleaning Shovel		CHG70099-50
Air Trap 4"		CHG70031-00
Air Trap 6"		CHG70031-50
MINI 100		
Closed End Cap for MINI100 (1 Galvanized Steel Part)		CHG70016-00
4" Pipe Connection (PVC) for MINI, TOP & MAXI100		CHG70021-00
TOP 100 & MAXI 100		
Closed End Cap for All TOP & MAXI100 (2 Parts: Plastic Support + Galvanized Steel Cap)		CHG70011-10
Closed End Cap for 6.30" TOP & MAXI100: (1 Iron Part)		CHG70011-11
Closed End Cap for 7.28" TOP & MAXI100: (1 Iron Part)		CHG70011-12
Open End Cap for All TOP&MAXI100 with Connection to 4" Pipe (2 Parts: Plastic Support + Galvanized Steel Cap)		CHG70011-20
4" Pipe Connection (PVC) for MINI, TOP & MAXI100		CHG70021-00
6" Oval Pipe Connection (PVC) for underneath TOP/MAXI100		CHG70021-60
MAXI 150		
End Cap for MAXI150 (Open & Closed) (1 Plastic Part to close MAXI150 trench drains of all depths that can be cut to connect 6" Pipes)		CHG70011-51
6" Pipe Connection (PVC) for MAXI150		CHG70021-50
MAXI 200 & MAXI 300		
End Cap for MAXI200 (Open & Closed) (1 Plastic Part to close MAXI200 trench drains that can be cut to connect 8" Pipes)		CHG70012-00
8" Pipe Connection (PVC) for MAXI 200 & MAXI300		CHG70022-00
Closed End Cap for MAXI300 (1 Iron Part)		CHG70031-11

FAQ's

1. What are HYDROTEC channels made of?

HYDROTEC channels are made of fiber reinforced concrete, which is sturdier than polymer concrete channels. This more durable material drastically reduces breakage during transportation and installation. Additionally, Hydrotec trench drains are made of the same material as the concrete bedding that surrounds them, which means that they respond to environmental and temperature changes in the same way. This reduces the risk of cracking and breakage due to fluctuations in heat, cold and moisture.

2. What different sizes are HYDROTEC trench drains available?

HYDROTEC trench drains are available in 39.37" (1 meter) and 19.69" (0.5 meter) long. HYDROTEC trench drains are available in 4", 6", 8" and 12" widths (throat or reveal width).

3. What is HYDROTEC trench drains country of origin?

HYDROTEC trench drains come from Germany.

4. What different HYDROTEC trench drains are there?

- The 4" wide MINI100 is a simple modular system for do-it-yourself installation with load class A and B galvanized steel grates.
- The 4" wide TOP100 is a sturdier system for pedestrian areas, parking lots, general commercial areas and athletic fields. They have galvanized steel edge rails and two types of grates available: galvanized steel (slot or mesh) in load class A and C; and heavier load class C ductile iron grates.
- The MAXI is the toughest of the line, ideal for heavy duty jobs thanks to its ductile iron edge rails and grates in load class C, D, E and F. The MAXI is available in 4" (MAXI100), 6" (MAXI150), 8" (MAXI200) and 12" (MAXI300).

5. Are HYDROTEC trench drains pre-sloped?

The 4" and 6" trench drains are available both flat and pre-sloped. The 8" and 12" trench drains are only available flat.

6. Are HYDROTEC trench drains available in different depths?

Yes, please consult our catalog for further details.

7. What materials and load classes are HYDROTEC grates are available in?

Grates are available in Galvanized Steel (Load Classes A, B and C) and in Ductile Iron (Load Classes C, D, E and F).

8. Are ADA grates available?

Yes, ADA grates are available in Galvanized Steel and Ductile Iron. Please consult our catalog for further details.

9. Are High Heel grates available?

Yes, High Heel grates are available for the MAXI 100 both in Galvanized Steel and in Ductile Iron.

FAQ's

10. How do HYDROTEC grates lock into the channel?

All TOP and MAXI trench drains come with the HYDROTEC patented locking mechanism by which a plastic rod is easily pushed under the grate and locks into the grate onto the channel. This system greatly reduces installation and maintenance time and costs.

All grates for the MINI trench drains are pushed onto the channel without the need of a locking mechanism.

11. What is the “F1” locking system?

With the “F1” locking system, the grate is bolted onto the channel. This system was developed for Formula 1 race circuits and meets the most rigorous requirements in high security areas.

12. How do two HYDROTEC trench drains connect to each other?

HYDROTEC trench drains come with a male/female built in profile so they can be easily connected.

13. What is the HYDROTEC trench drain installation process?

HYDROTEC trench drains are easy and quick to install. The trench drains do not need to be hung or suspended, they are simply placed in a stable base and concrete is poured around them. This process, along with HYDROTEC patented locking mechanism, significantly reduces the time spent by the crew completing the job.

14. Do HYDROTEC trench drains require a concrete encasement?

All MINI, TOP and MAXI trench drains require a concrete encasement. Please refer to our Installation Instructions for further details.

15. Are HYDROTEC trench drains liquid tight?

Yes, HYDROTEC fiber reinforced concrete channels are liquid tight to EN 1433 standard.

16. Can we install HYDROTEC trench drains in an angle? How about on a curve?

A 45 degree angle can be created by using one of the special channels that come with an exit on the side. HYDROTEC fiber reinforced concrete channels and galvanized steel or ductile iron grates can be cut onsite to create any angle other angle.

HYDROTEC trench drains can be installed in a curve. Please refer to the catalog for further details.

17. Can we close HYDROTEC trench drains with an End Cap?

Yes, all MINI, TOP and MAXI trench drains have End Caps available to close the trench drains at both ends.

FAQ's

18. How can we connect a pipe to a HYDROTEC trench drain?

There are three ways to connect a pipe to a HYDROTEC trench drain:

1. From Underneath the Channel: All MINI, TOP and MAXI come with a precast knock out that can be easily removed to connect the channel to a pipe from underneath the channel using HYDROTEC adaptors. Please refer to the table below for pipe sizes.
2. At either End of the Channel: All MINI, TOP and MAXI (except MAXI300) can be connected to a pipe at either end of the channel using HYDROTEC end caps. Please refer to table below for pipe sizes.
3. At the side of the Channel: All MINI, TOP and MAXI (except MAXI300) can be connected to a pipe from the side of the channel using a special 19.69" (0.5 meter) part. Please refer to the table below for pipe sizes.

Model	Channel Width (Throat or Reveal)	Pipe Connection		
		From Underneath the Channel	At Both Ends of the Channel	From Side of the Channel
MINI100	4"	4"	4"	Not Available
TOP100	4"	4" / 6"	4"	4"
MAXI100	4"	4" / 6"	4"	4"
MAXI150	6"	6"	6"	6"
MAXI200	8"	6"	8"	8"
MAXI300	12"	8" upon request	Closed	Not Available

19. Are Catch Basins available?

Yes, Catch Basins are available for all HYDROTEC Trench Drains.

20. What is HYDROline?

HYDROline is a 39.37" (1 meter) flat drainage channel made of one ductile iron piece that is extremely easy to install as it sits directly on top of the concrete.

21. What is HYDROblock?

HYDROblock is a one-piece trench drain system in which the channel and the grate are cast together out of ductile iron. HYDROblock is load class F and it is available in 4", 8" and 12" wide.

22. Where can I find out more about HYDROTEC trench drains price and availability?

Please contact your SIGMA representative.

23. Where can I find more information about HYDROTEC trench drains?

Please go to www.sigmaco.com/hydrotec or contact your SIGMA representative.

Supplied By:

**TRENCHDRAIN
SUPPLY**

877-903-7246

www.trenchdrainsupply.com



Precast Concrete Trench Drain Solutions

INSTALLATION INSTRUCTIONS

HYDROTEC 

Technologies

Rev 4/30/15

GENERAL INSTALLATION INSTRUCTIONS

1 Ensure that the trench where the channels are going to be installed has enough room for the appropriate concrete encasement, depending on the Load Class and the installation materials. Lay the a concrete bed according to the instructions in this manual.

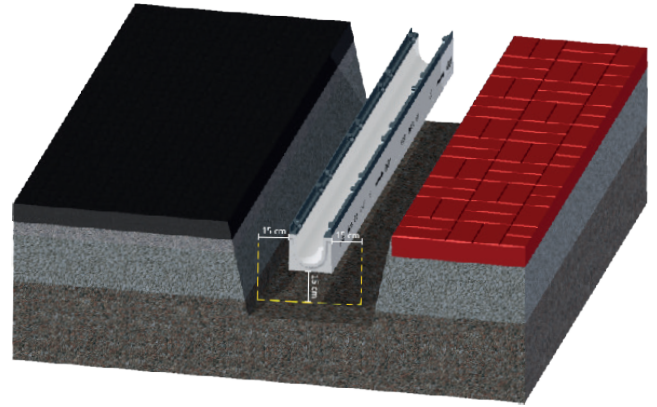

Installation Example MAXI Load Class C

2 Unlock and remove the grates. Prior to laying the trench drains, please make sure that the concrete bed is strong enough as per this manual. The trench drains must be laid starting from the last piece, whether this is a catch basin or not, and in the opposite direction than the flow of water.

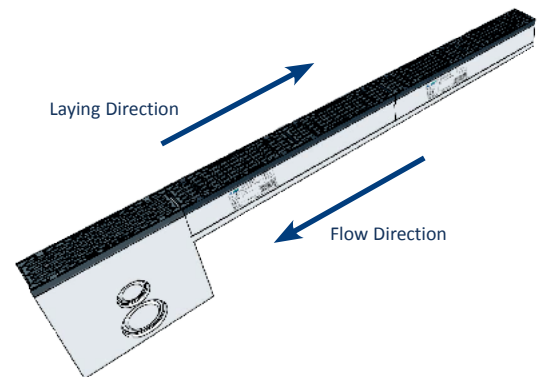

3 Each trench drain comes with directional arrows that indicate the direction of the flow of water. Trench drains adjust together thanks to their male and female profiles. Pre-sloped channels are marked with a number from 1 to 10 to indicate their place in a continuous slope run.

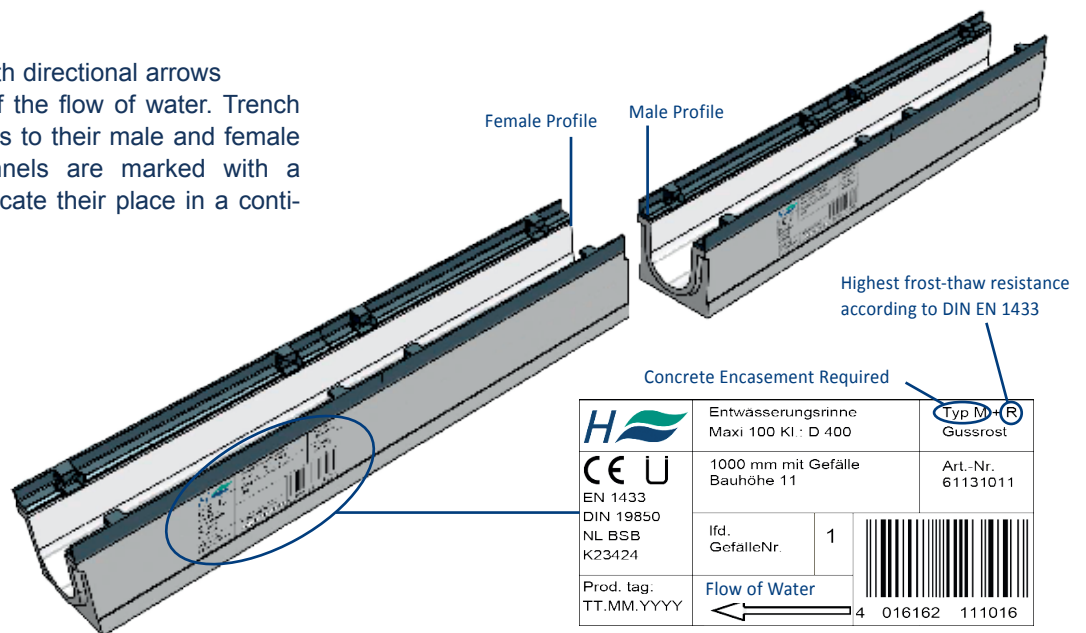

INSTALLATION INSTRUCTIONS

- 4 All HYDROTEC trench drains come with a precast knock out underneath to connect a pipe. Place the channel on two wooden pieces and use and carefully hammer out the proforma pipe connector from inside the channel. See manual for specific instructions.

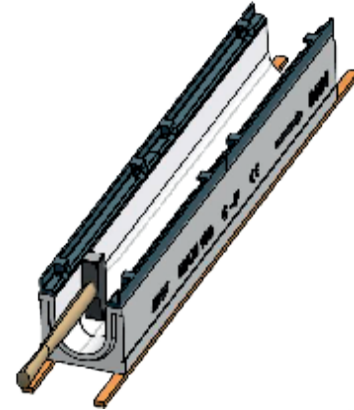

- 5 Once the trench drains have been installed, end caps can be used to either close the channel or connect it to a pipe. See manual for specific instructions.

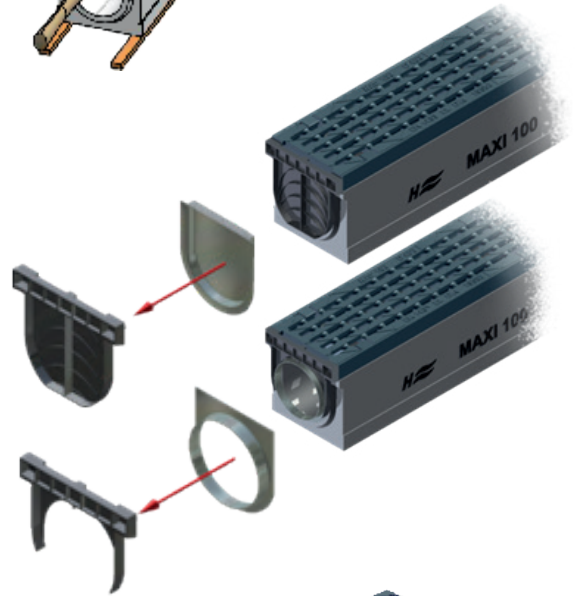

- 6 Place back the grates on top of the channels before finalizing the concrete encasement, as the grates will protect the channel against horizontal forces.

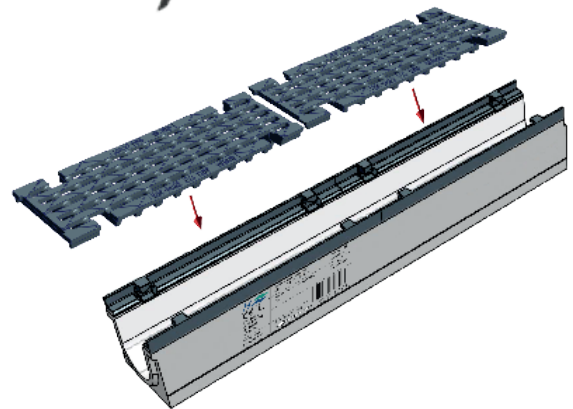

- 7 When laying the adjacent pavement is particularly important to ensure that the top of the drainage channel is between 0.12" and 0.20" [3-5 mm] lower than the adjacent surface, depending on the trench drain type and installation as per this manual.

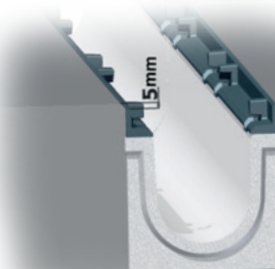

EXPANSION JOINTS ARRANGEMENT

If the project drawings do not specify any guidelines for expansion joints, we recommend the arrangement of expansion joints as shown in the following diagram:

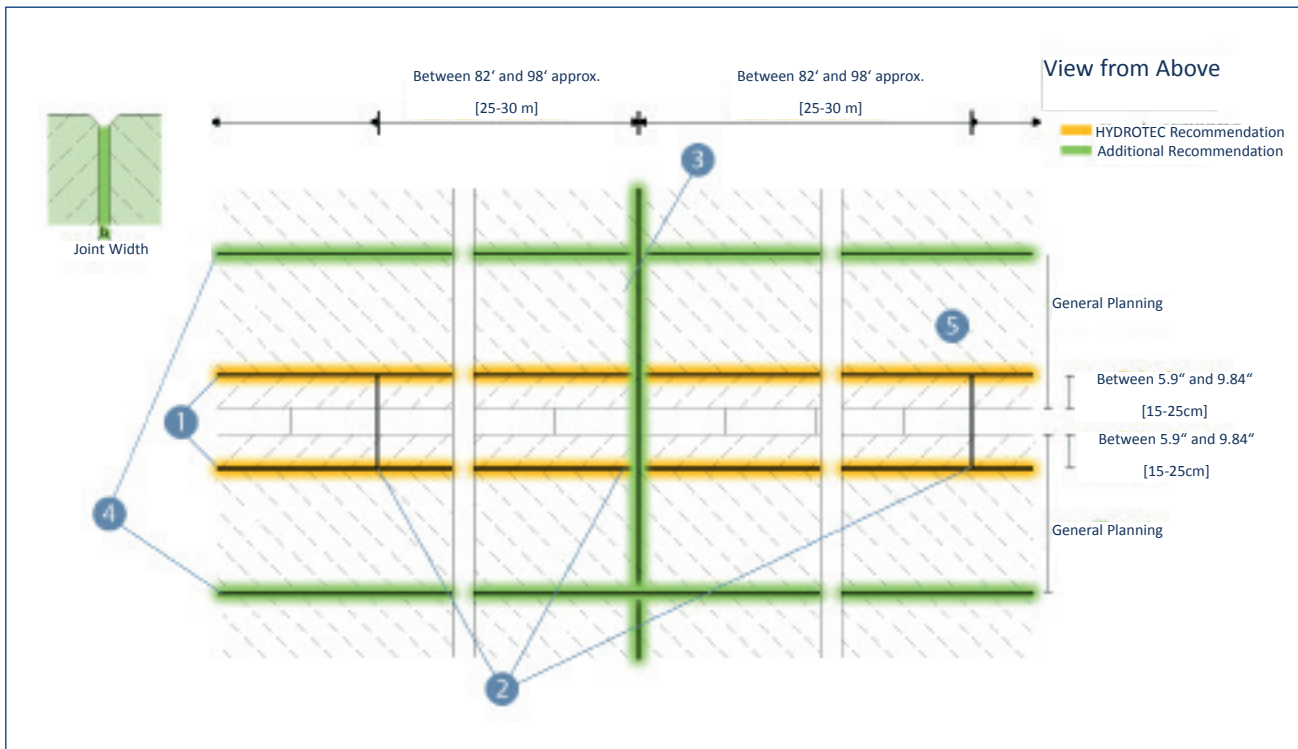

- ① The placement of expansion joints depends on the trench drain selected for each construction project. We recommend to place the seam on the outside edge of the concrete coating.
- ② Expansion joints should always be placed perpendicular to the channel line. We recommend a distance of approximately 82' - 98' [25 - 30 m] between expansion joints. The joint width shall be determined by the engineer responsible of the plan.
- ③ In the arrangement of expansion joints in the concrete road surface, it is important to adhere exclusively to the guidelines of the project managers union planner or architect.
- ④ Further expansion joints may be placed parallel to the channel line according to the project's engineer.
- ⑤ Concrete road surface

Supplied By:

**TRENCHDRAIN
SUPPLY**

877-903-7246

www.trenchdrainsupply.com

TRENCH DRAIN RUNS LAYOUT

Flat Trench Drain Run (No Slope)

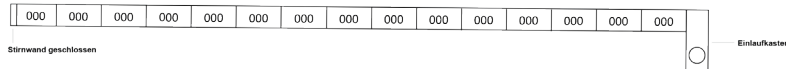

The trench drain run is straight, the water flows helped by the ground fall. The water discharges through a catch basin.

Flat Trench Drain Run at Different Heights

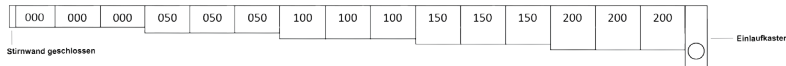

Through a combination of trench drains of different heights, a constant flow of water is possible. The trench drain run can be connected to a pipe through an open end cap.

Pre-Sloped Trench Drain Run

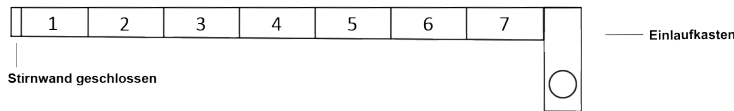

The water flow is affected by a continuous slope. The trench drains have an internal pre-slope between 0.5% and 1%, depending on the model. The trench drain run can be connected to a pipe through an open end cap.

Pre-sloped Trench Drain Runs in Opposite Directions

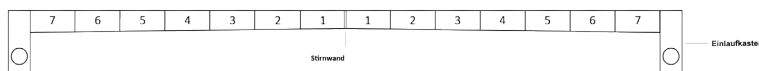

Two pre-sloped trench drain runs start in opposite directions from the middle of the section. To avoid a gap in the middle, remove the male profile of the first pieces or use closed end caps.

Runoff / water table / floor training

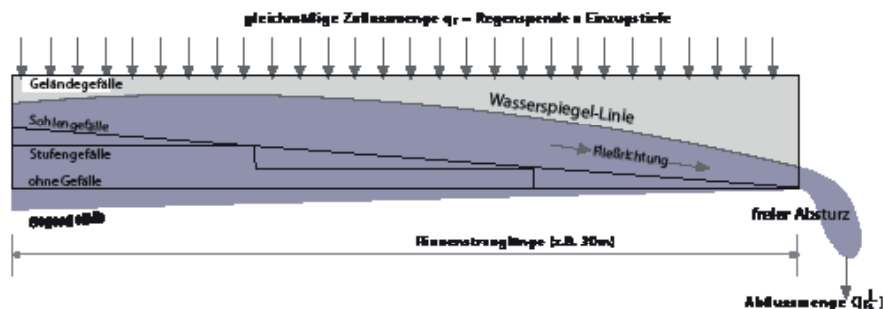

Whether the trench drains are flat or pre-sloped has not real effect on the water runoff. The water discharge rate is determined only by the channel cross-section at the end of the run.

INSTALLATION INSTRUCTIONS MINI



3 When the channel is installed on a concrete bed, it is protected against the horizontal forces. This requires a concrete shell of 3.93"[10 cm] width and 2.36"[6 cm] height.

5 The top edge of the channel must be at approximately the following distances below the adjoining surface:
Asphalt 0.19"[5 mm]
Concrete = 1/8"[3 mm]

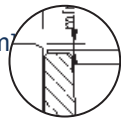

4 The areas on the right and left along the channel are to be laid in fresh concrete and then shed with grout.

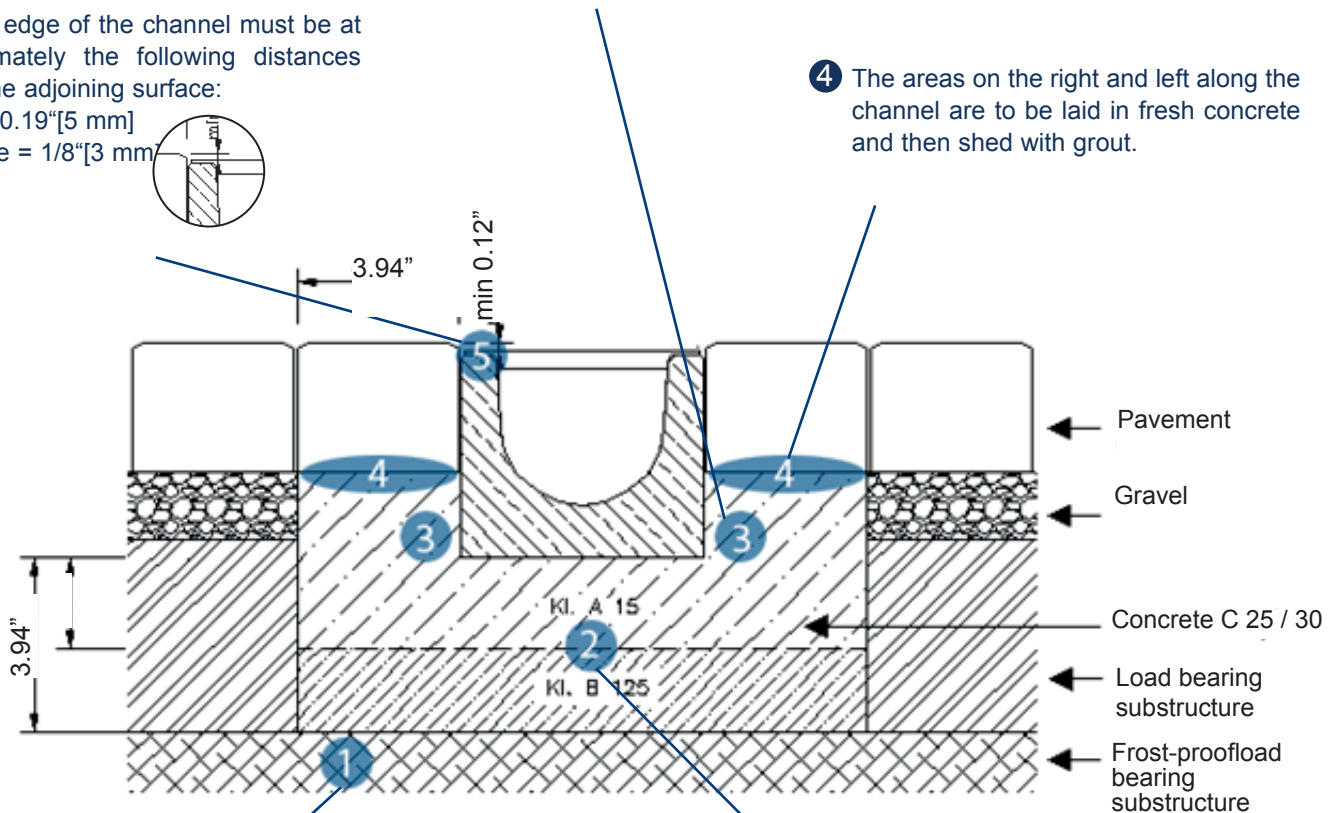

1 Before beginning work, ensure the load bearing base is frost free. The base must therefore be properly compacted according to the load class to avoid the channel to drop upon installation. Usually this is determined by the structural engineer responsible for the project or planner.

2 When installing the MINI system, a C25/30 concrete bed must be built according to the load class (A or B): for Load Class A, the concrete bed must be of at least 1.92"[5cm]; for Load Class B the concrete bed must be of at least 3.93"[10cm].

INSTALLATION INSTRUCTIONS

TOP LOAD CLASS A-C WITH ASPHALT



④ The upper edge of the channel must be about 0.2" [5 mm] lower than the adjacent surface.

③ The concrete bed where the channels is sitting serves as protection against horizontal forces. A 45 degree angle to the top of the channel is recommended.

⑤ The Asphalt layer has minimum contact with the channel to ensure that there are no horizontal forces acting on the channel.

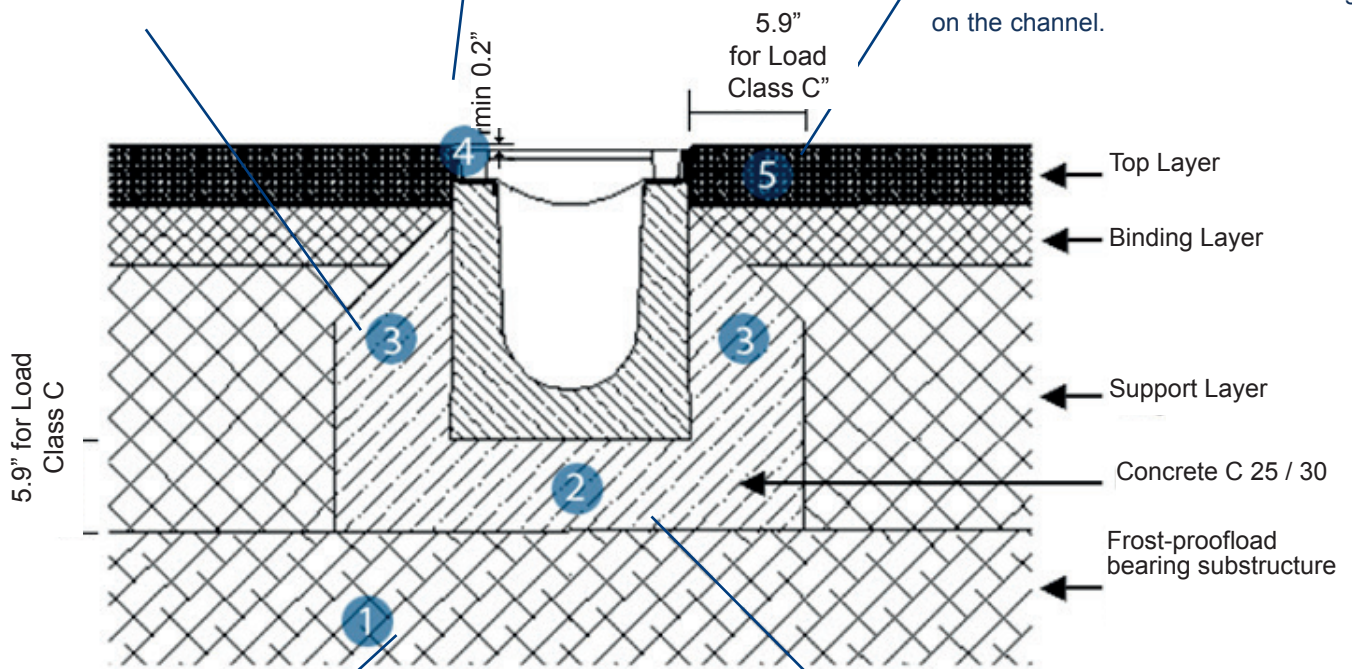

① Before beginning work, ensure the load bearing base is frost free. The base must therefore be properly compacted according to the load class to avoid the channel to drop upon installation. Usually this is determined by the structural engineer responsible for the project or planner.

② When installing the TOP system, a C25/30 concrete bed must be built according to the load class (A, B or C): for Load Class A or B, the concrete bed must be of at least 3.93" [10cm]; for Load Class C the concrete bed must be of at least 5.9" [15cm].

INSTALLATION INSTRUCTIONS

TOP LOAD CLASS A-C WITH ASPHALT / STONE / BRICK



- ④ The runner stone is to be laid in fresh concrete shed with concrete and mortar. The top of the stone must be at least 0.12" [3mm] higher than the channel.

- ③ The concrete bed where the channels is sitting serves as protection against horizontal forces. The concrete on the sides of the channels must be at least 5.9" [15cm] in width.

- ⑤ The curb needs to lay on fresh concrete and then shed with grout.

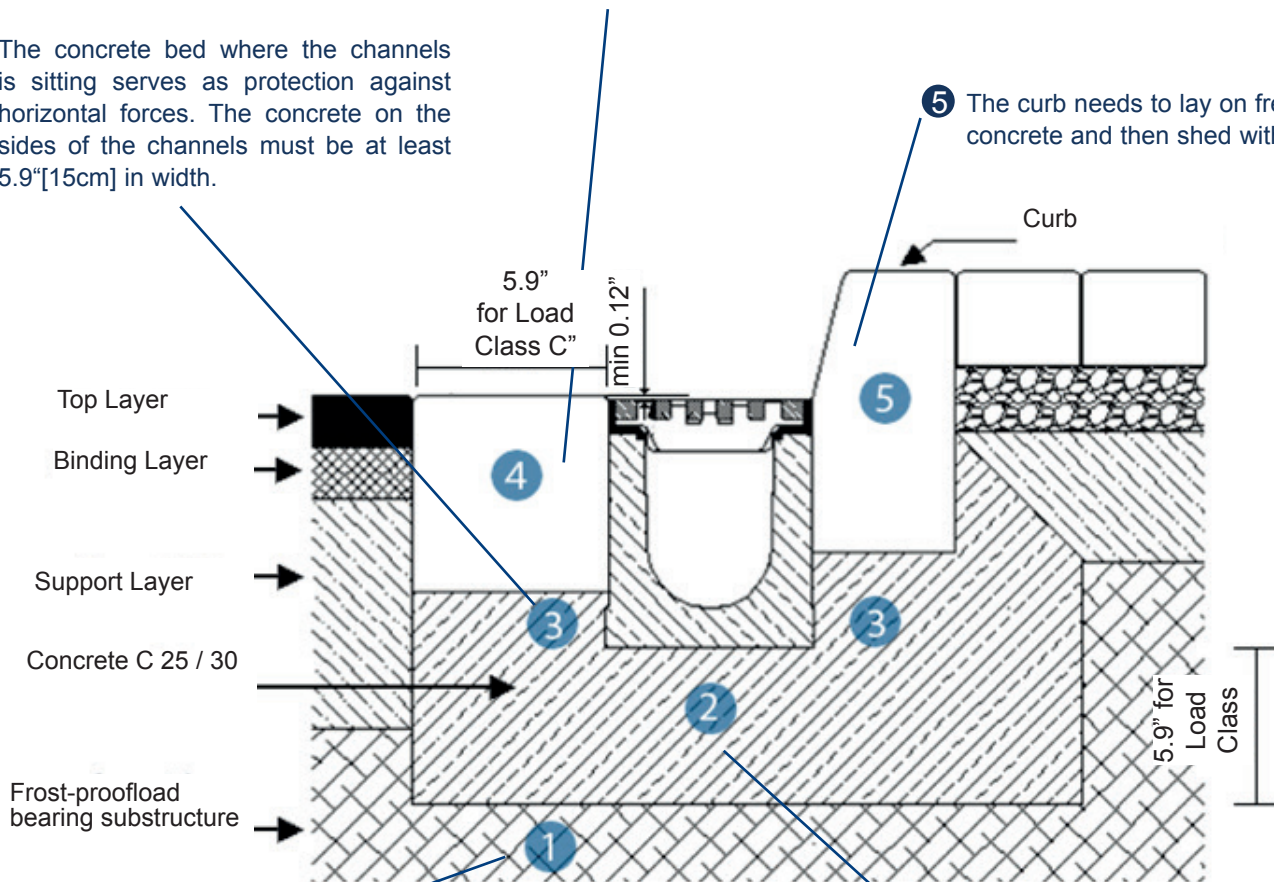

- ① Before beginning work, ensure the load bearing base is frost free. The base must therefore be properly compacted according to the load class to avoid the channel to drop upon installation. Usually this is determined by the structural engineer responsible for the project or planner.

- ② When installing the TOP system, a C25/30 concrete bed must be built according to the load class (A, B or C): for Load Class A or B, the concrete bed must be of at least 3.93" [10cm]; for Load Class C the concrete bed must be of at least 5.9" [15cm].

INSTALLATION INSTRUCTIONS

TOP LOAD CLASS A-C WITH CONCRETE / PAVEMENT



④ Approximately 5.9"[15 cm] from the outer edge of the channel, we recommend creating a joint with styrofoam to allow for expansion

③ The concrete bed where the channels is sitting serves as protection against horizontal forces. The concrete on the sides of the channels must be at least 5.9"[15cm] in width and 4.72"[12cm] in height.

⑤ Ideally, the first two rows of paving must be laid in fresh concrete and then shed with grout.

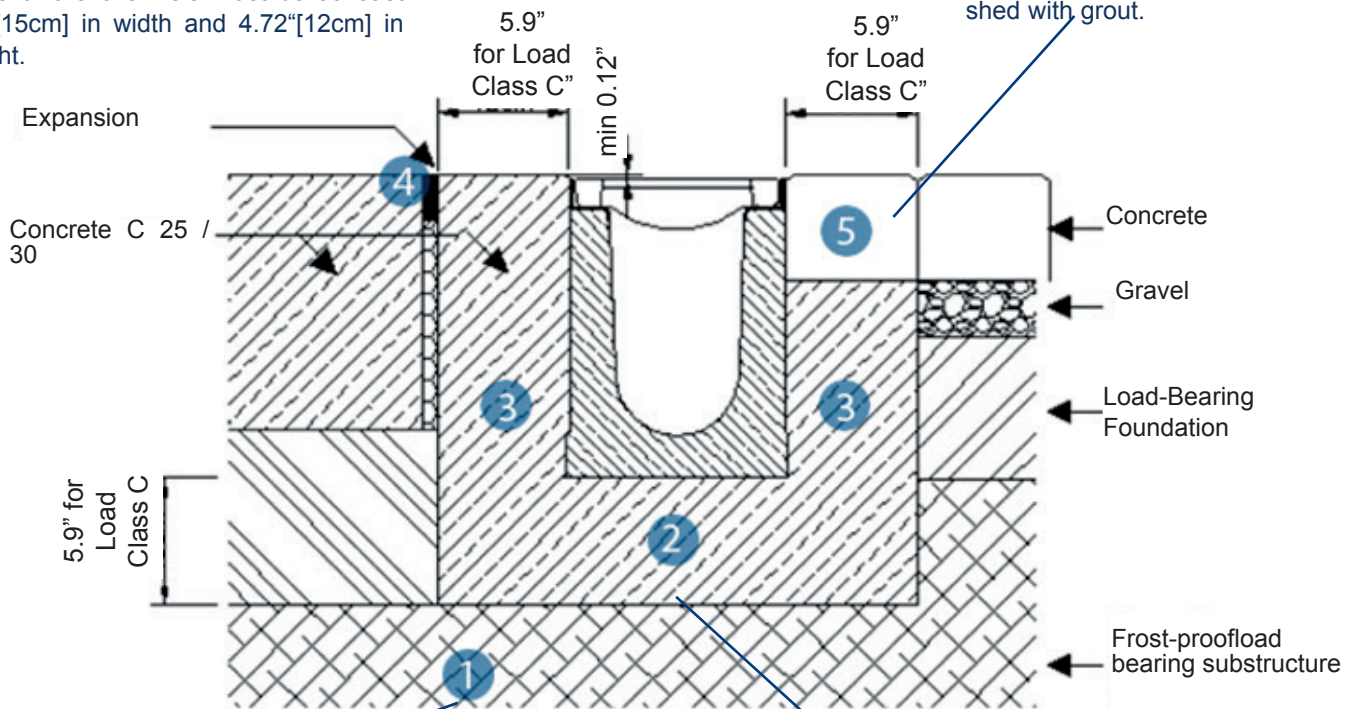

① Before beginning work, ensure the load bearing base is frost free. The base must therefore be properly compacted according to the load class to avoid the channel to drop upon installation. Usually this is determined by the structural engineer responsible for the project or planner.

② When installing the TOP system, a C25/30 concrete bed must be built according to the load class (A, B or C): for Load Class A or B, the concrete bed must be of at least 3.93"[10cm]; for Load Class C the concrete bed must be of at least 5.9"[15cm].

INSTALLATION INSTRUCTIONS

MAXI LOAD CLASS A-C WITH ASPHALT

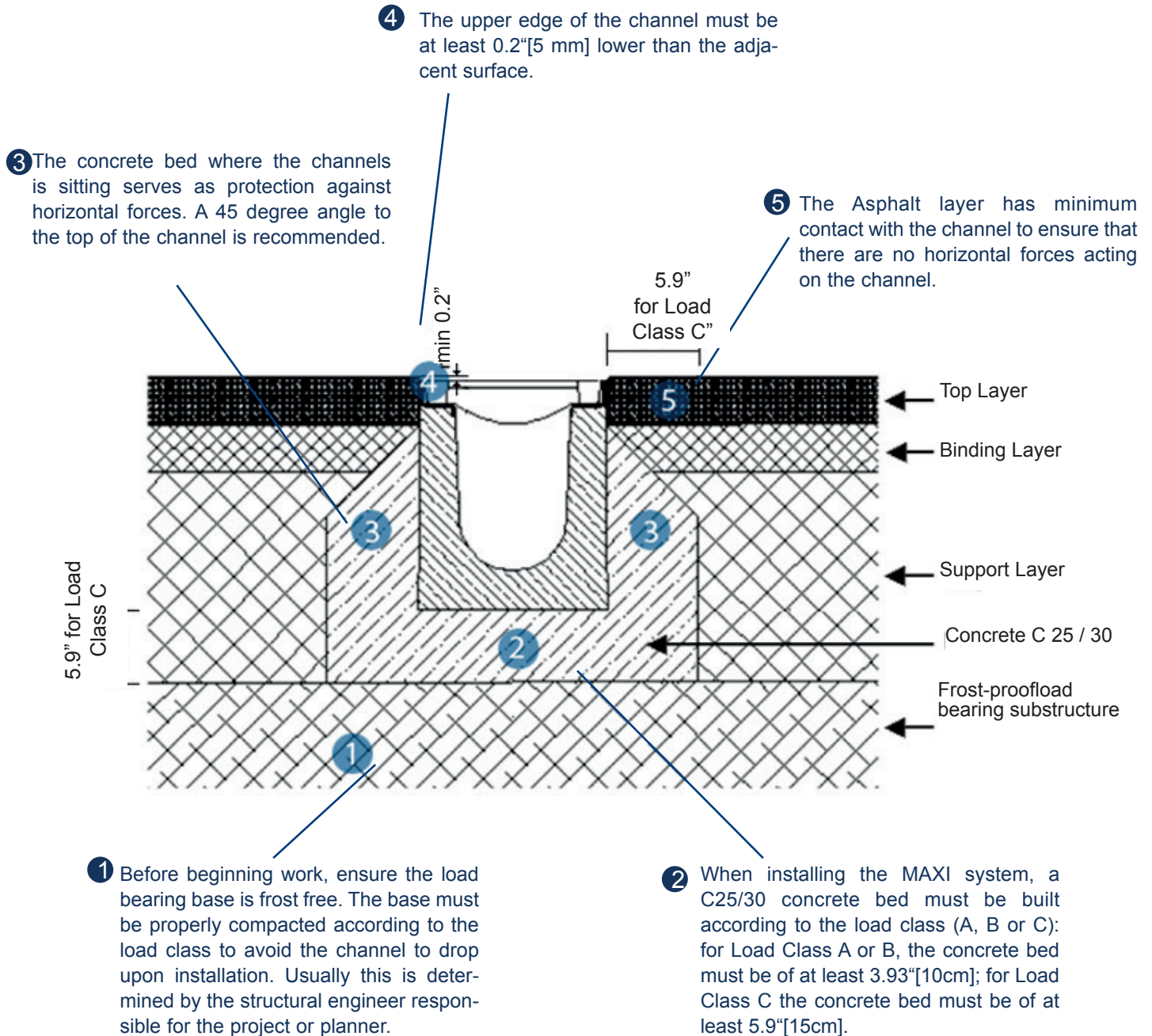

Supplied By:

**TRENCHDRAIN
SUPPLY**

877-903-7246

www.trenchdrainsupply.com

INSTALLATION INSTRUCTIONS

MAXI LOAD CLASS A-C WITH ASPHALT / STONE / BRICK



④ The runner stone is to be laid in fresh concrete shed with concrete and mortar. The top of the stone must be at least 0.12"[3mm] higher than the channel.

③ The concrete bed where the channels is sitting serves as protection against horizontal forces. The concrete on the sides of the channels must be at least 5.9"[15cm] in width.

⑤ The curb needs to lay on fresh concrete and then shed with grout.

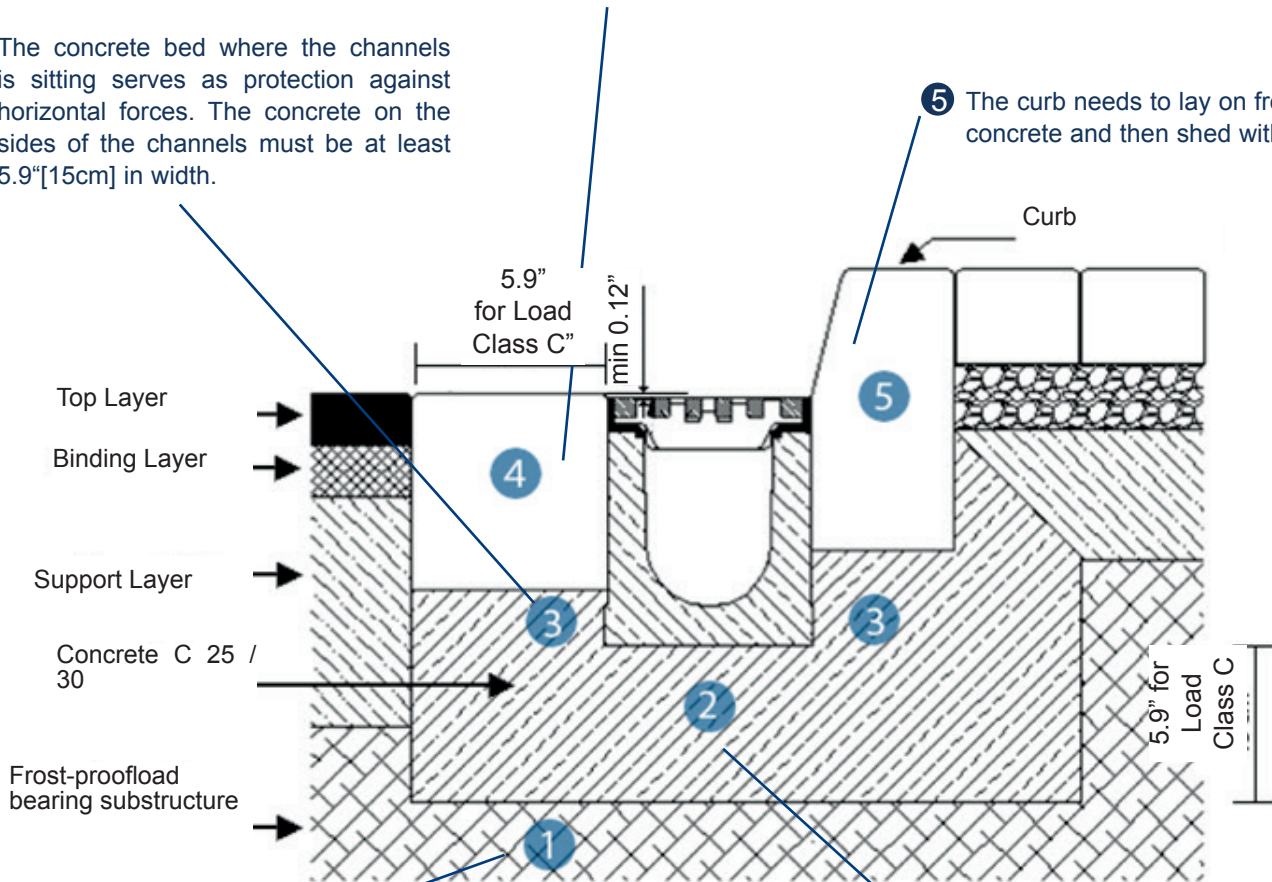

① Before beginning work, ensure the load bearing base is frost free. The base must be properly compacted according to the load class to avoid the channel to drop upon installation. Usually this is determined by the structural engineer responsible for the project or planner.

② When installing the MAXI system, a C25/30 concrete bed must be built according to the load class (A, B or C): for Load Class A or B, the concrete bed must be of at least 3.93"[10cm]; for Load Class C the concrete bed must be of at least 5.9"[15cm].

INSTALLATION INSTRUCTIONS

MAXI LOAD CLASS A-C WITH CONCRETE / PAVEMENT



④ Approximately 5.9" [15 cm] from the outer edge of the channel, we recommend creating a joint with styrofoam to allow for expansion due to temperature fluctuations.

③ The concrete bed where the channels is sitting serves as protection against horizontal forces. The concrete on the sides of the channels must be at least 5.9" [15cm] in width and 4.72" [12cm] in height.

⑤ Ideally, the first two rows of paving must be laid in fresh concrete and then shed with grout.

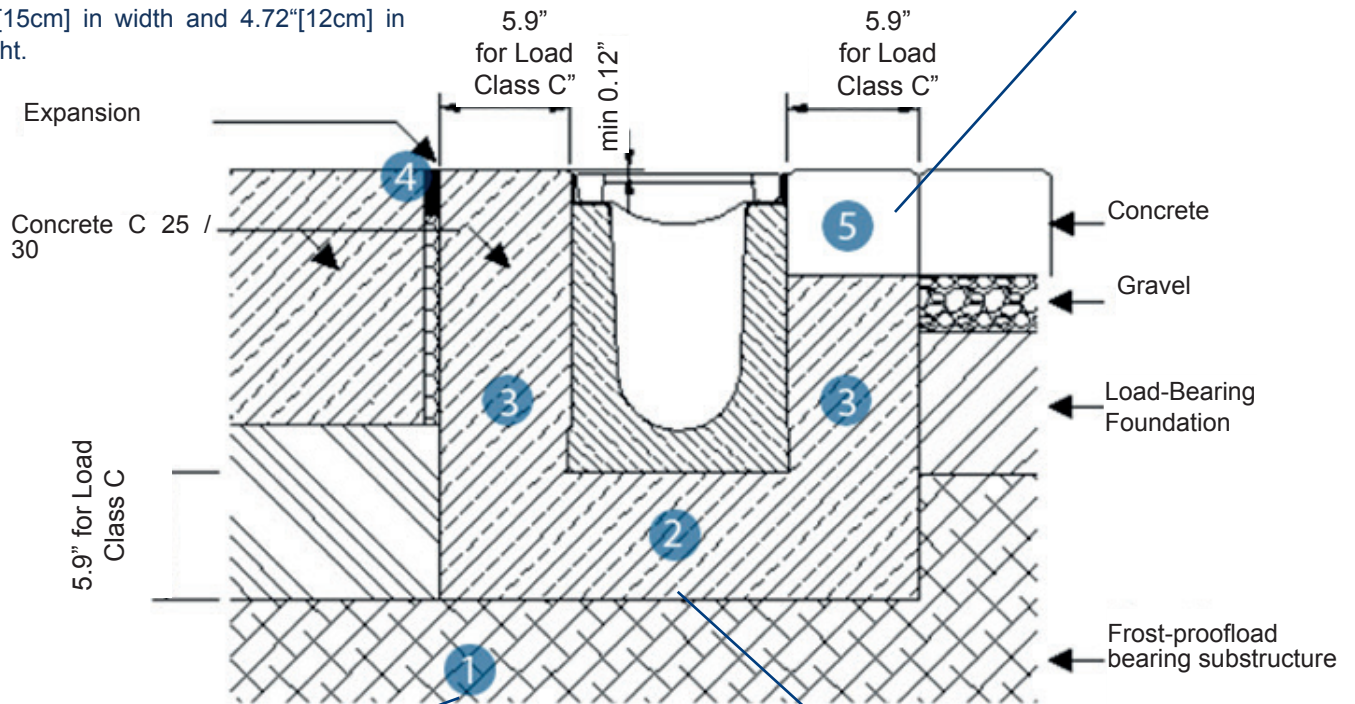

① Before beginning work, ensure the load bearing base is frost free. The base must be properly compacted according to the load class to avoid the channel to drop upon installation. Usually this is determined by the structural engineer responsible for the project or planner.

② When installing the MAXI system, a C25/30 concrete bed must be built according to the load class (A, B or C): for Load Class A or B, the concrete bed must be of at least 3.93" [10cm]; for Load Class C the concrete bed must be of at least 5.9" [15cm].

INSTALLATION INSTRUCTIONS

MAXI LOAD CLASS D - E - F



The concrete bed where the channels is sitting serves as protection against horizontal forces. The concrete on the sides of the channels must be at least 5.9"[15cm] in width and 4.72"[12cm] in height. For critical points in Load Classes E and F, we recommend an additional reinforcement, such as \varnothing 0.3"[8mm] bars at intervals of 11.8" [300mm].

Approximately between 5.9"[15 cm] and 7.9" [20cm] (depending on the load class) from the outer edge of the channel, we recommend creating a joint with styrofoam to allow for expansion due to temperature fluctuations.

The upper edge of the channel must be at least 0.12"[3 mm] lower than the adjacent surface.

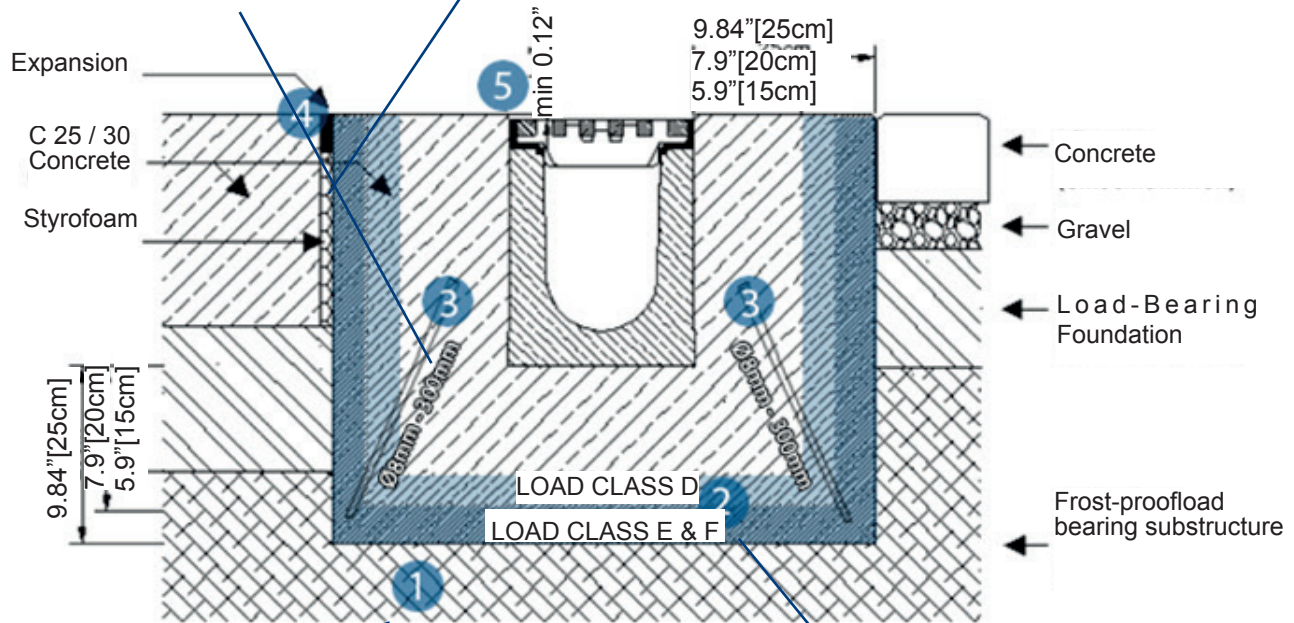

1 Before beginning work, ensure the load bearing base is frost free. The base must be properly compacted according to the load class to avoid the channel to drop upon installation. Usually this is determined by the structural engineer responsible for the project or planner.

2 When installing the MAXI system, a C25/30 concrete bed must be built according to the load class (D, E or F): for Load Class D, the concrete bed must be of at least 7.9"[20cm]; for Load Class E or F the concrete bed must be of at least 9.84"[25cm]. For high stress points we recommend to reinforce the concrete bed.

HYDROline

If the conditions of point 1 and 2 are satisfied, HYDROline can be installed using concrete (C25/30). The anchors underneath HYDROline secure the part to the concrete.

Approximately 7.9"[20 cm] from the outer edge of the channel, we recommend creating a joint with styrofoam to allow for expansion due to temperature fluctuations.

The upper edge of the channel must be 0.12"[3 mm] lower than the adjacent surface.

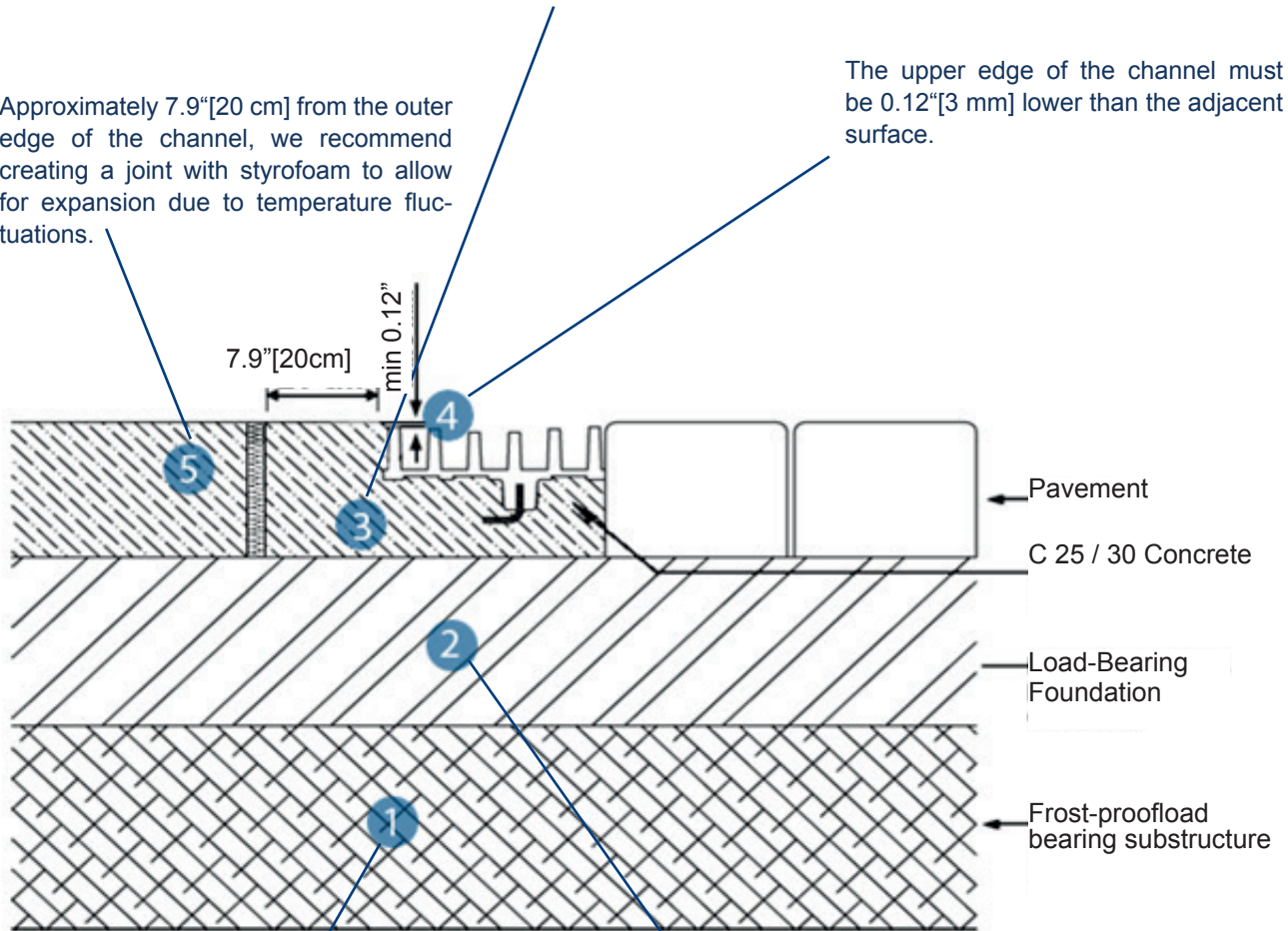

Before beginning work, ensure the load bearing base is frost free. The base must therefore be properly compacted according to the load class to avoid the channel to drop upon installation. Usually this is determined by the structural engineer responsible for the project or planner.

Prerequisite for the installation of HYDROline is an existing foundation for load transfer. The dimension and thickness of the foundation is based on the structural analysis of each construction project, as well as at the selected load class.

INSTALLATION INSTRUCTIONS

HYDROline

The shallow HYDROline is suitable for installation into an existing opening (eg for renovation) or as a new trench drain installation run in concrete using the installation aids. Depending on the required load class the existing base course must be reviewed and approved by the architect / planner.

Installation on an Existing Trench

Fill the existing hole with fresh concrete and set the HYDROline on top of it. Add an end wall at the beginning and end of the run if needed.



Starting by the end of the run, the individual pieces are connected together using a connecting piece. Each HYDROline piece easily snaps onto the next piece.



The channel line must be at least 0.12" [3mm] deeper than the adjacent surface.

Installation as a New Trench Drain Run

When installing HYDROline as a new trench drain run, we recommend using the built-in supports from HYDROTEC. The mounting bracket serves as connecting piece between parts, a perfect fit for installation on level.



The built-in supports need to be placed in between each HYDROline piece. Add an end wall at the beginning and end of the run if needed.



Prior to installation of the concrete layer, HYDROline should be covered and masked to prevent the entry of concrete. The upper edge of the channel must be 0.12" [3 mm] lower than the adjacent surface.

HYDROblock

The upper edge of the channel must be at least 0.07" [2 mm] lower than the adjacent surface.

Depending on the nature of the adjacent material, the use of tape for sealing is required. The need for tape is determined by the planner or project manager of each construction project.

It is recommended to reinforce the channel with a mounting support made of concrete class C25 / 30. Otherwise HYDROblock can be fixed to the foundation with screws on the feet.

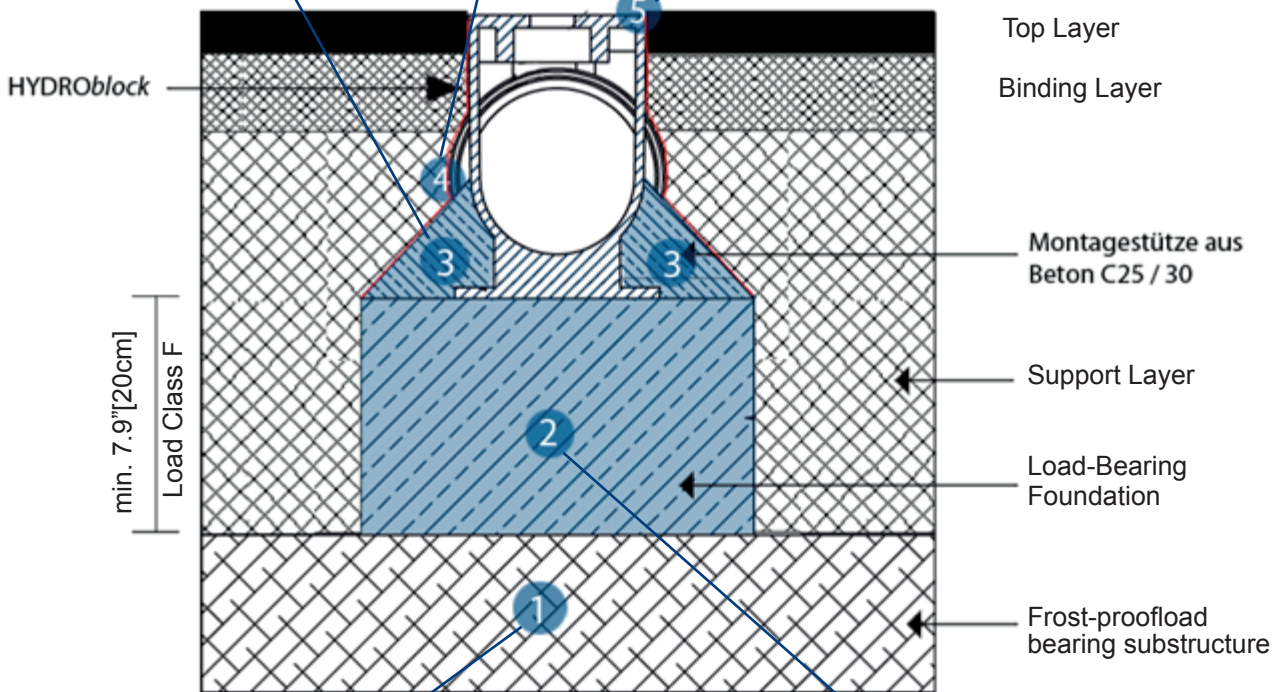

Before beginning work, ensure the load bearing base is frost free. The base must be properly compacted according to the load class to avoid the channel to drop upon installation. Usually this is determined by the structural engineer responsible for the project or planner.

When installing HYDROblock a load-bearing foundation of a minimum of 7.9" [20 cm] is required.

The use of a commercial sealant between pieces is recommended.



INSTALLATION INSTRUCTIONS

HYDROblock



1
The concrete base is created according to the required load class to lay HYDROblock.



4
The HYDROblock parts are pushed one inside the other.

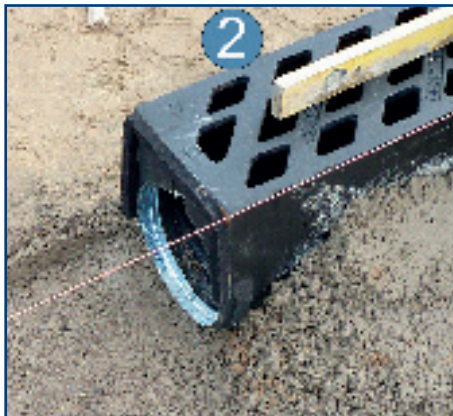

2
Before the parts can be joined together, sealant needs to be applied to the sleeve.



5
After the connecting the parts, they are set at the intended height.



3
The HYDROblock pieces are joined together easily thanks to their male / female profiles.



6
Verify that the parts are flat as intended.

Installation Instructions

The trench drain type depends on the installation location, the corresponding traffic loads, and the decking planned. Installation locations are organized in classes A to F according to EN 1433 standard. As of class C all grates must be anchored to ensure traffic safety. The foundation of the trench drain must be suitable to bear the traffic load.

Horizontal loads arising from traffic or thermal behavior of the surface layer must be transferred by means of sufficiently dimensioned concrete encasement of the channel sections and by expansion joints running longitudinally to the channel, especially in case of adjoining concrete surfaces.

The laying direction of the channel is always opposite to the direction of flow and starts at the ground pipe joint. Subsequent surfaces must be executed to be approx. 0.11" (3mm) to 0.19" (5 mm) higher than the top edge of the grate or edge rail taking setting and compression into account.

If extreme horizontal forces are expected at right angles to the trench drain, e.g. on railway crossings, ramps or highways, the trench drains should be secured laterally with reinforced decking concrete.

MINI / TOP / MAXI channel systems are manufactured to comply with EN 1433 Type M standard. This design requires a load bearing foundation and / or encasement to be able to absorb vertical and horizontal loads after installation. See installation instructions.

The HYDROblock channel system is manufactured in line with EN 1433 Type I. Concrete encasement is not required. This type requires a load-bearing foundation.

Fitting Direction

The laying direction of the channel is always opposite to the direction of flow (green arrows!) and starts at the ground pipe joint. If elements are laid in two directions it is necessary to join two counterfacing elements. To avoid a gap remove the profile rebate with an angle grinder or use end pieces.

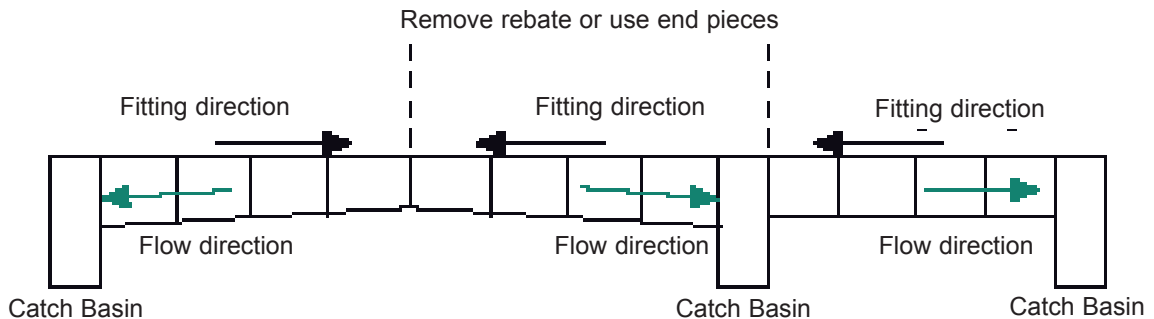

Precast Vertical Outlet to connect a Pipe in every Trench

All MINI, TOP and MAXI trench drains have a precast outlet for a pipe connection in the base of every channel. The precast can be knocked out carefully using a hammer, after placing the channel on wooden supports leaving a space underneath. Matching PVC pipe connections are available and allow for an easy connection of the channel to the pipe systems.



Precast Outlet in the channel base for 4", 6" and 8" pipe connection:
MINI/TOP/MAXI 100: 4" and 6"
MAXI150 / MAXI 200: 6"
MAXI300: 8"

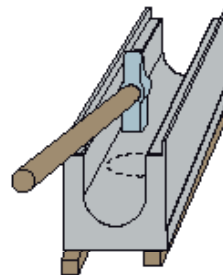

Knock out gently

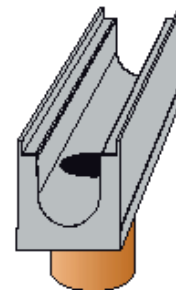

Insert the PVC pipe connection so it does not go all the way through the channel

End Cap Installation Instructions

End Caps are available for all HYDROTEC Trench Drain systems. Depending on the model, the trench drain can be connected to a 4", 6" or 8" pipe. The PVC Connector is only needed to connect a pipe underneath the channel.

Closed End Cap for MINI100

1. Remove the grate
2. Take Part No. CHG70016-00, place the galvanized steel piece inside the channel so the round male side fits inside the channel.
3. Place back the grate on top of the channel and push it down to lock it.

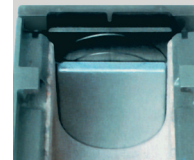

Closed End Cap for TOP100 / MAXI100

1. Unlock and remove the grate using HYDROTEC's Grate Locking Tool (Part. No. CHG70099-00).
2. Take Part No. CHG70011-10: place the galvanized steel piece inside the channel so the round male side fits inside the channel.
3. Place the plastic piece against the galvanized steel piece so the hooks on top of the plastic piece rest on the edge rails of the channel.
4. Place back the grate on top of the channel and lock it.

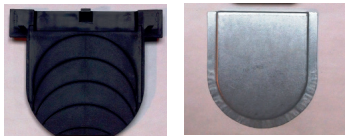

Plastic Piece & Galvanized Steel Piece together form Part No. CHG70011-10



Connecting a 4" Pipe to an End Cap for MINI100 / TOP100 / MAXI100

1. Unlock and remove the grate using HYDROTEC's Grate Locking Tool (Part. No. CHG70099-00).
2. Take Part No. CHG70011-20: place the galvanized steel piece against the channel so the round male side points outside the channel.
3. Cut the plastic piece following the pre-cut guides so it fits the size of the 4" round male galvanized steel part.
4. Place the plastic piece outside the galvanized steel piece so the hooks on the top of the plastic piece rest on the edge rails of the channel.
5. Insert the 4" pipe into the galvanized steel piece.
6. Place the grate on top of the channel and lock it.

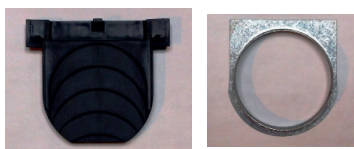

Plastic Piece & Galvanized Steel Piece together form Part No. CHG70011-20



Closing or Connecting a 6" Pipe to an End Cap for MAXI150

1. Unlock and remove the grate using HYDROTEC's Grate Locking Tool (Part. No. CHG70099-00).
2. Take Part. No. CHG70011-51: place the plastic piece outside the galvanized steel piece so the hooks on the top of the plastic piece rest on the edge rails of the channel.
 - 3a. To Close the Trench Drain: cut the plastic piece following the pre-cut guides so it fits the height of the channel. Place the grate on top of the channel and lock it.
 - 3b. To Connect a 6" pipe to the end of the Trench Drain: Cut the plastic piece following the pre-cut guides so it fits the size of the 6" Pipe.
4. Insert the 6" Pipe into the plastic piece.
5. Place the grate on top of the channel and lock it.



Closing or Connecting a 8" Pipe to an End Cap for MAXI200

1. Unlock and remove the grate using HYDROTEC's Grate Locking Tool (Part. No. CHG70099-00).
2. Take Part No. CHG70012-00, and place it against the channel so the hooks on the top of the plastic piece rest on the edge rails of the channel.
 - 3a. To Close the Trench Drain: Place the grate on top of the channel and lock it.
 - 3b. To Connect a 8" pipe to the end of the Trench Drain: Cut the plastic piece following the pre-cut guides so it fits the size of the 8" Pipe.
4. Insert the 8" Pipe into the plastic piece.
5. Place the grate on top of the channel and lock it.



Closing the MAXI300

1. Unlock and remove the grate using HYDROTEC's Grate Locking Tool (Part. No. CHG70099-00).
2. Take Part No. CHG70031-11, and place it against the channel so the channel is closed.



Connecting a Pipe to a Catch Basin

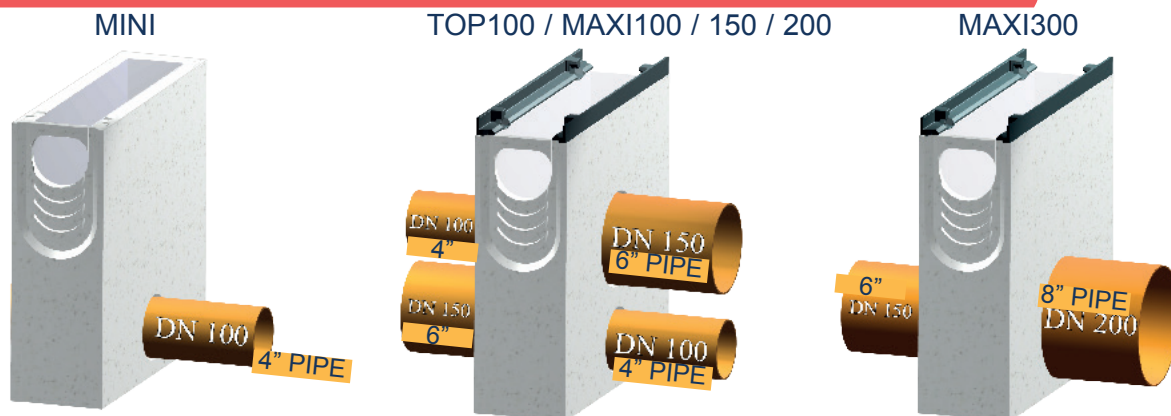

Installing HYDROTEC Trench Drain in a 90 Degree Angle

The TOP and MAXI lines include a 19.69" (0.5m) parts with a hole on the side. These pieces can be used to create a 90 degree angle or a 4 way cross.

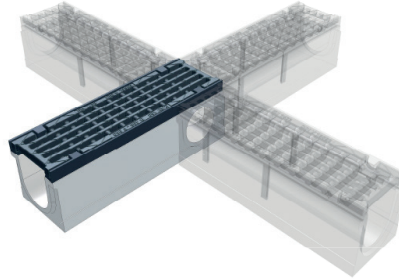

Installing HYDROTEC Trench Drain in a Different Angle

HYDROTEC's fiber reinforced channels and Galvanized Steel and Ductile Iron grates can be cut onsite to create the appropriate angle..

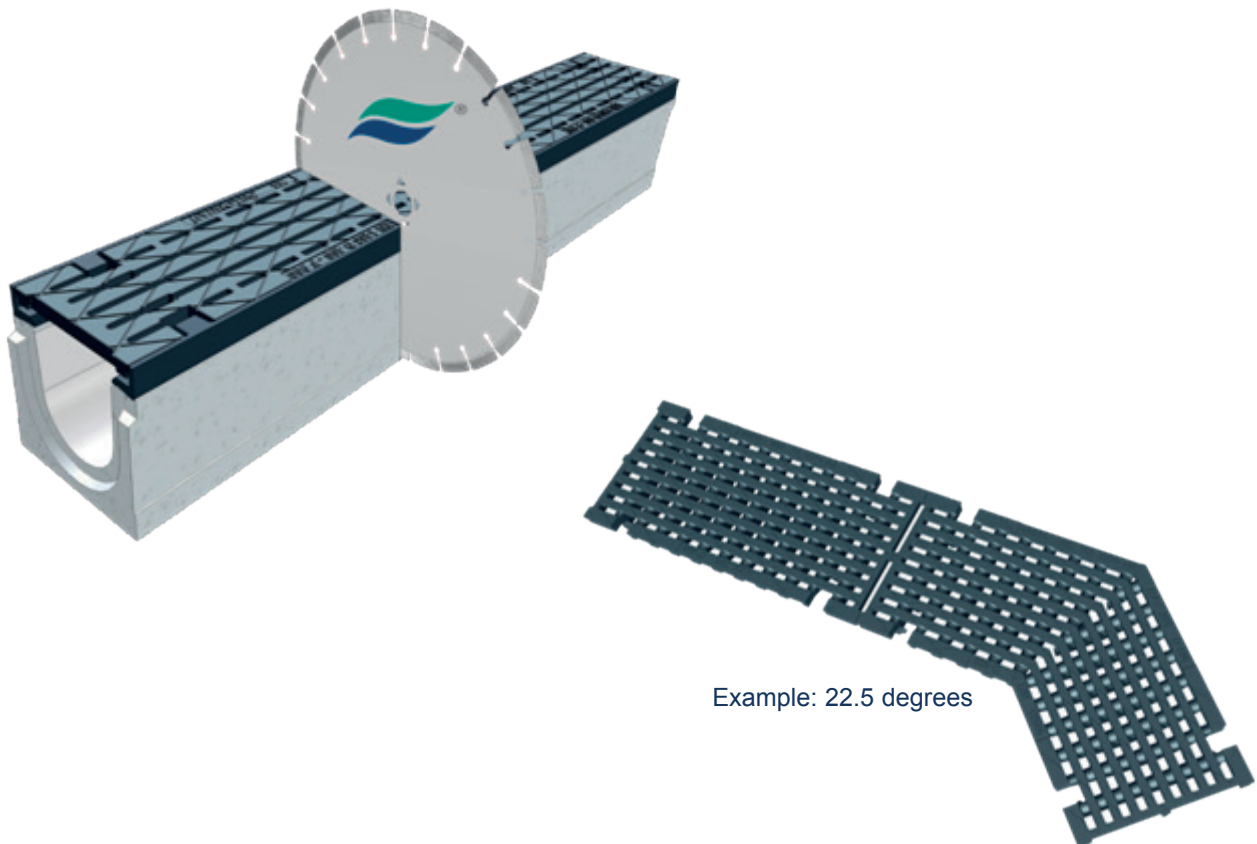

Example: 22.5 degrees

Installing HYDROTEC's Trench Drains in a Radius

HYDROTEC Trench Drains can be installed in a radius by following the following instructions.

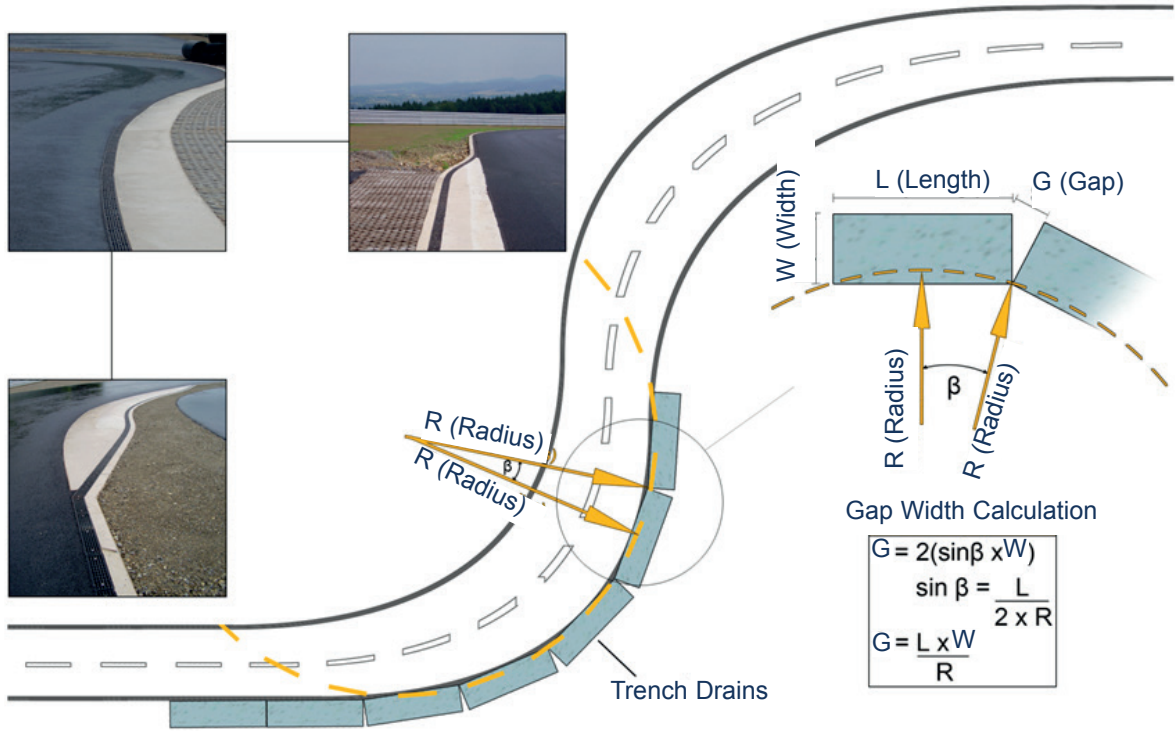

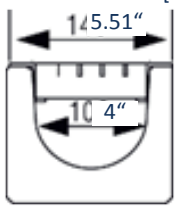
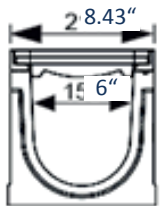
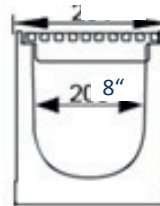
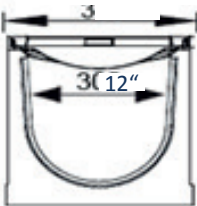
Radius R Feet [meters]	Trench Drain Length L Inches							
	Throat Width 4"[100]		Throat Width 6"[150]		Throat Width 8"[200]		Throat Width 3"	
								
16.4'[5.0]	0.55"[14.0]	1.10"[28.0]	0.84"[21.4]	1.69"[42.8]	1.04"[26.4]	2.08"[52.8]	1.53"[38.8]	3.06"[77.6]
24.61'[7.5]	0.37"[9.3]	0.74"[18.7]	0.56"[14.3]	1.12"[28.5]	0.69"[17.6]	1.39"[35.2]	1.02"[25.9]	2.04"[51.7]
32.81'[10.0]	0.28"[7.0]	0.55"[14.0]	0.42"[10.7]	0.84"[21.4]	0.52"[13.2]	1.04"[26.4]	0.76"[19.4]	1.53"[38.8]
49.21'[15.0]	0.19"[4.7]	0.37"[9.3]	0.28"[7.1]	0.56"[14.3]	0.35"[8.8]	0.69"[17.6]	0.51"[12.9]	1.02"[25.9]
65.62'[20.0]	0.14"[3.5]	0.28"[7.0]	0.21"[5.4]	0.42"[10.7]	0.26"[6.6]	0.52"[13.2]	0.38"[9.7]	0.76"[19.4]
82.02'[25.0]	0.11"[2.8]	0.22"[5.6]	0.17"[4.3]	0.34"[8.6]	0.21"[5.3]	0.42"[10.6]	0.31"[7.8]	0.61"[15.5]
98.43'[30.0]	0.09"[2.3]	0.19"[4.7]	0.14"[3.6]	0.28"[7.1]	0.17"[4.4]	0.35"[8.8]	0.26"[6.5]	0.51"[12.9]
	0.08"[2.0]	0.16"[4.0]	0.12"[3.1]	0.24"[6.1]	0.15"[3.8]	0.30"[7.5]	0.22"[5.5]	0.44"[11.1]

Gap G [mm]

Gap too large Max. Gap Recommended Optimal Gap

MINI – Load Class A - B with Plaster



Surface compacting: **Plaster**

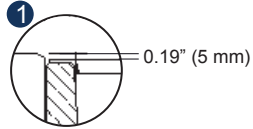

The edge protector in the drainage channel must be permanently seated approx. 5 mm lower than the adjoining surface.

Lay the stretchers in fresh concrete and then backfill

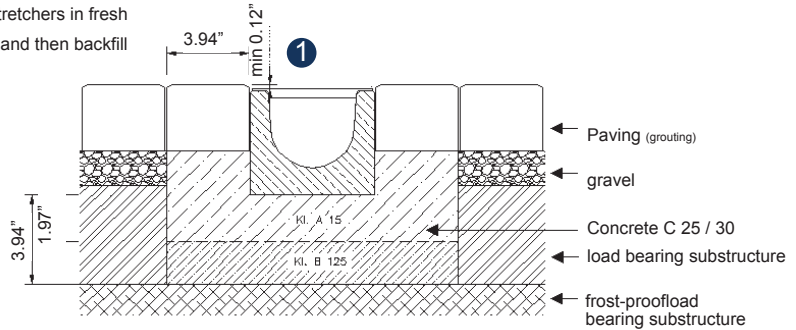

TOP / MAXI – Load Class A - B - C with Asphalt / Kerb / Concrete / Paving



Surface compacting: **Asphalt**

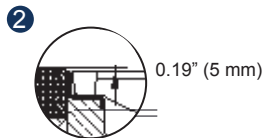

The edge protector in the drainage channel must be permanently seated approx. 5 mm lower than the adjoining surface.

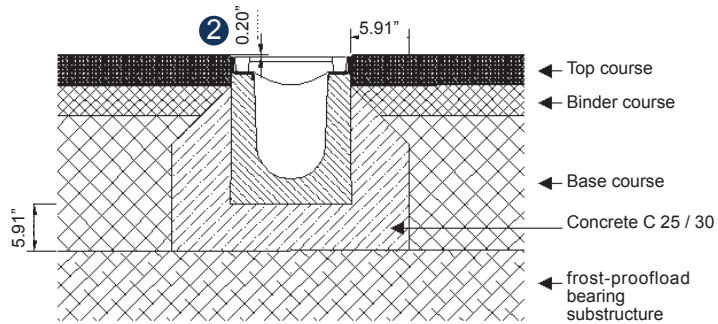

Surface compacting: **Asphalt / Kerb**

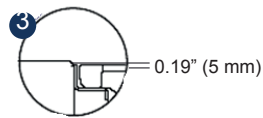

The edge protector in the drainage channel must be permanently seated approx. 5 mm lower than the adjoining surface.

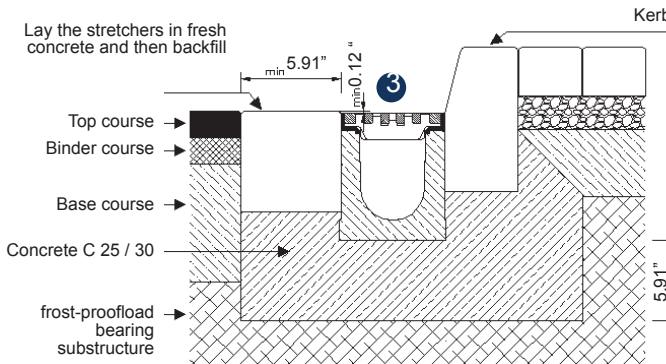

Surface compacting: **Roadway Concrete / Paving**

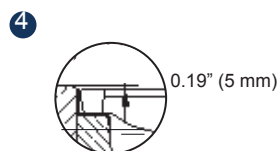

The edge protector in the drainage channel must be permanently seated approx. 5 mm lower than the adjoining surface.

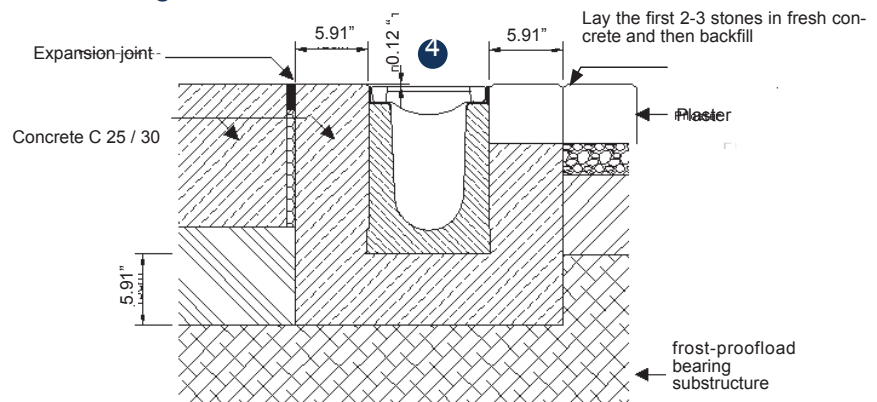

INSTALLATION INSTRUCTIONS
MAXI 100 / 150 / 200 / 300 HYDROblock 100 / 200

MAXI – Load Class D - E - F with Concrete / Paving



Surface compacting: **Roadway Concrete / Paving**

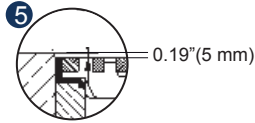

The edge protector in the drainage channel must be permanently approx. 5 mm lower than the neighboring surface.

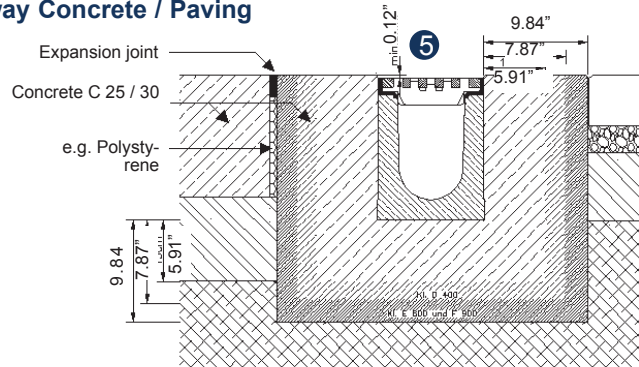

- Concrete strength of encasement at least C 25 / 30.
- The expansion joint width must be executed to reflect the local conditions.
- In case of installation locations with extreme loads, reinforcement of the encasement is recommended

frost-proofload bearing substructure

MAXI – Load Class C - D - E - F with Asphalt



Surface compacting: **Asphalt**

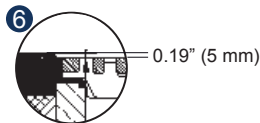

The edge protector in the drainage channel must be permanently approx. 5 mm lower than the neighboring surface.

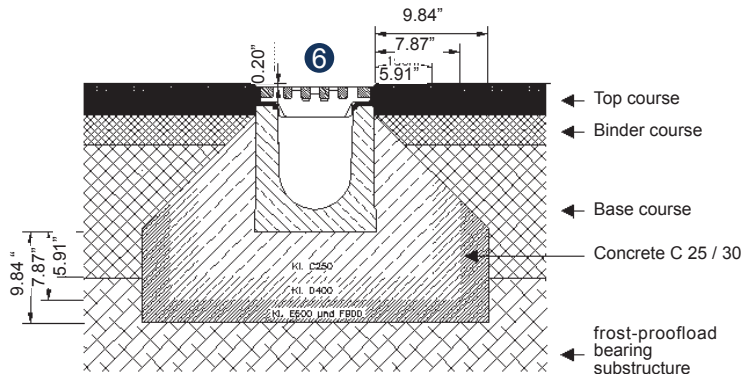

- ← Top course
- ← Binder course
- ← Base course
- ← Concrete C 25 / 30

frost-proofload bearing substructure

HYDROblock - Load Class F



If necessary: circumferential jointing tape to seal the neighboring surface

The surface of the HYDROblock channel must be permanently seated approx. 0.08 ins lower than the adjoining surface.

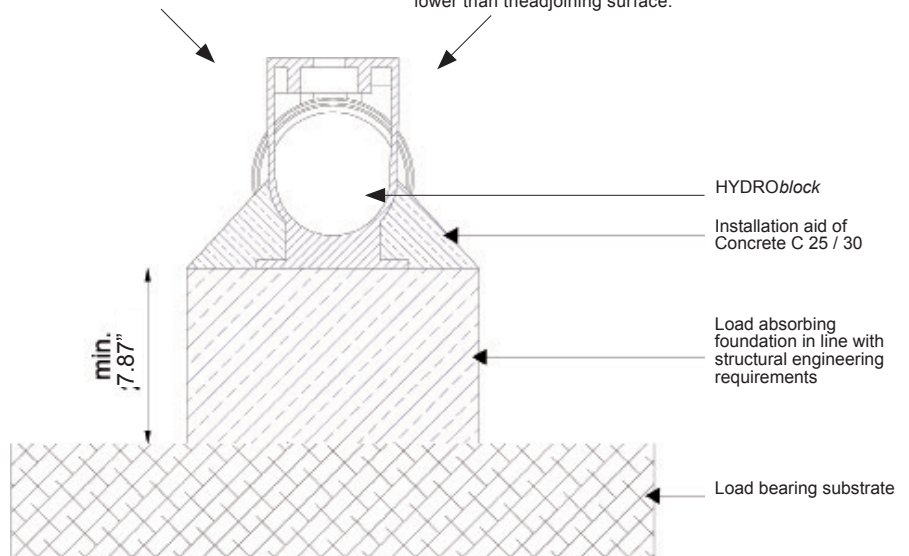

HYDROblock
Installation aid of
Concrete C 25 / 30

Load absorbing
foundation in line with
structural engineering
requirements

Load bearing substrate